

4K@60/HDCP 2.2 HDBaseT Extender with Distribution Amplifier

HDC-UHD Series

HDC-TR121UHD
HDC-TH221UHD/HDC-TH421UHD
HDC-RH221UHD/HDC-RH421UHD

<User Guide>

Ver.1.0.0

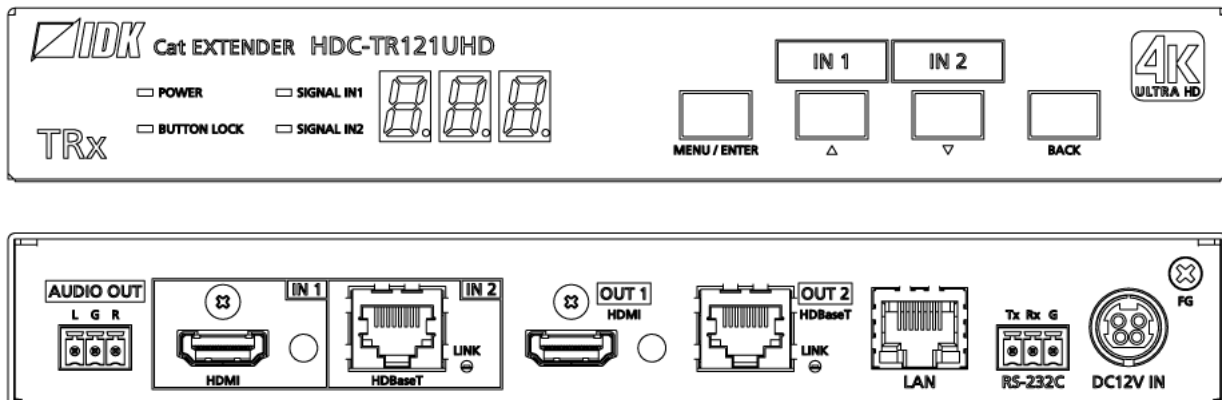

- Thank you for choosing our product.
- To ensure the best performance of this product, please read this user guide fully and carefully before using it and keep this manual together with the product for future reference as needed.

IDK Corporation

Trademarks

- Blu-ray Disc and Blu-ray are trademarks of Blu-ray Disc Association.
- ETHERNET is a registered trademark of Fuji Xerox Co., Ltd.
- Google Chrome is trademark or registered trademark of Google Inc.
- HDBaseT™ and the HDBaseT Alliance Logo are trademarks of the HDBaseT Alliance.
- The terms HDMI and HDMI High-Definition Multimedia Interface, and the HDMI Logo are trademarks or registered trademarks of HDMI Licensing Administrator, Inc. in the United States and other countries.
- Javascript® is a trademark or registered trademark of Oracle Corporation, its subsidiaries, and affiliated companies in the United States and other countries.
- Microsoft, Windows, Internet Explorer are either registered trademarks or trademarks of the Microsoft Corporation in the United States and other countries.
- The terms Mozilla and Firefox, and their logos are registered trademarks or trademarks of Mozilla Foundation in the United States and other countries.
- Oracle and Java are trademarks of Oracle Corporation its subsidiaries, and affiliated companies in the United States and other countries.
- The terms Anti-snow and Connection Reset are registered trademarks of IDK Corporation in Japan.
- All other company and product names mentioned in this manual are either registered trademarks or trademarks of their respective owners. In this manual, the “®” or “™” marks may not be specified.

Before reading this manual

- All rights reserved.
- Some information contained in this User guide such as exact product appearance, diagrams, menu operations, and so on may differ depending on the product version.
- This User guide is subject to change without notice. You can download the latest version from IDK's website at: <http://www.idkav.com>

The reference manual consists of the following two volumes:

- User guide (this document):
Provides explanations and procedures for operations, installation, connections among devices, I/O adjustment and settings.
- Command guide: Please download the command guide from the website above.
Provides explanations and procedures for external control using RS-232C and LAN communications.

FCC STATEMENT

This equipment has been tested and found to comply with the limits for a Class A digital device, pursuant to part 15 of the FCC Rules. These limits are designed to provide reasonable protection against harmful interference when the equipment is operated in a commercial environment. This equipment generates, uses, and can radiate radio frequency energy and, if not installed and used in accordance with the instruction manual, may cause harmful interference to radio communications. Operation of this equipment in a residential area is likely to cause harmful interference, in which case the user will be required to correct the interference at his own expense.

CE MARKING

This equipment complies with the essential requirements of the relevant European health, safety and environmental protection legislation.

WEEE MARKING











Waste Electrical and Electronic Equipment (WEEE), Directive 2002/96/EC
(This directive is only valid in the EU.)

This equipment complies with the WEEE Directive (2002/96/EC) marking requirement.
The left marking indicates that you must not discard this electrical/electronic equipment in domestic household waste.

Safety Instructions

Read and understand all safety and operating instructions before using this product. Follow all instructions and heed all warnings/cautions.

Enforcement Symbol	Description
 Warning	Indicates the presence of a hazard that may result in death or serious personal injury if the warning is ignored or the product is handled incorrectly.
 Caution	Indicates the presence of a hazard that may cause minor personal injury or property damage if the caution is ignored or the product is handled incorrectly.



Symbol	Description	Example
 Caution	This symbol is intended to alert the user. (Warning and caution)	 Electrical Hazard
 Prohibited	This symbol is intended to prohibit the user from specified actions.	 Do not disassemble
 Instruction	This symbol is intended to instruct the user.	 Unplug

Warning





■ For lifting heavy products:

 Instruction	<ul style="list-style-type: none"> ● Lifting must be done by two or more personnel. <p>To avoid injury: When lifting the product, bend your knees, keep your back straight and get close to it with two or more persons.</p>
---	--

■ For installing and connecting products:

 Prohibited	<ul style="list-style-type: none"> ● Do not place the product upon a surface that may give way or that may become unstable. <p>Install the product in a secure and stable place to prevent it from falling and possibly causing injury.</p> <ul style="list-style-type: none"> ● Secure the product if installing in locations prone to vibration or movement. <p>Otherwise, it may move unexpectedly or it may fall and lead to injury.</p>
 Instruction	<ul style="list-style-type: none"> ● Installation work must be performed by professionals. <p>The product is intended to be installed by skilled technicians. For installation, please contact a system integrator or IDK. Improper installation may lead to the risk of fire, electric shock, injury, or property damage.</p> <ul style="list-style-type: none"> ● Insert the power plug into an outlet that is unobstructed. <p>Unobstructed access to the plug enables unplugging the product in case of any extraordinary failure, abnormal situation or for easy disconnection during extended periods of non-use.</p> <ul style="list-style-type: none"> ● Insert the power plug into an appropriate outlet completely. <p>If the plug is partially inserted, arcing may cause the connection to overheat, increasing the risk of electrical shock or fire. Do not use a damaged plug or connect to a damaged outlet.</p> <ul style="list-style-type: none"> ● Unplug the product from the AC power source during installation or service. <p>When connecting peripheral devices to this product, unplug all involved devices from outlets. Ground potential differences may cause fire or other difficulties.</p>

■ For operating products:

 Prohibited	<ul style="list-style-type: none"> ● Keep out any foreign objects. <p>To avoid fire or electric shock, do not permit foreign objects, such as metal and paper, to enter the product from vent holes or other apertures.</p> <ul style="list-style-type: none"> ● For power cable/ plug: <ul style="list-style-type: none"> • Do not scratch, heat, or modify, including splicing or lengthening them. • Do not pull, place heavy objects on them, or pinch them. • Do not bend, twist, tie or clamp them together forcefully. <p>Misuse of the power cable and plug may cause fire or electric shock. If power cables/plugs become damaged, contact your IDK representative.</p>
 Do not disassemble	<ul style="list-style-type: none"> ● Do not repair, modify or disassemble. <p>Since the product includes circuitry that uses potentially lethal, high voltage levels, disassembly by unauthorized personnel may lead to the risk of fire or electric shock. For internal inspection or repair, contact your IDK representative.</p>
 Do not touch	<ul style="list-style-type: none"> ● Do not touch the product and connected cables during electrical storms. <p>Contact may cause electric shock</p>
 Instruction	<ul style="list-style-type: none"> ● Clean the power plug regularly. <p>If the plug is covered in dust, it may increase the risk of fire.</p>

Warning

■ **If the following problem occurs:**



- **Unplug immediately if the product smokes, makes unusual noise, or produces a burning odor.**

If you continue to use the product under these conditions, it may cause electric shock or fire.

- **Unplug immediately if the product is damaged by falling or having been dropped.**

If you continue to use the product under these conditions, it may increase the risk of electrical shock or fire. For maintenance and repair, contact your IDK representative.



- **Unplug immediately if water or other objects are directed inside.**

If you continue to use the product under these conditions, it may increase the risk of electrical shock or fire. For maintenance and repair, contact your IDK representative.



Caution

■ For installing and connecting products:

 <p>Prohibited</p>	<ul style="list-style-type: none"> ● Do not place the product in a location where it will be subjected to high temperatures. If the product is subjected to direct sunlight or high temperatures while under operation, it may affect the product's performance and reliability and may increase the risk of fire. ● Do not store or operate the product in dusty, oil smoke filled, or humid place. If the product is placed near humidifiers or in a dusty area, it may increase the risk of fire or electric shock. ● Do not block the vent holes. If ventilation slots are blocked, it may cause the product to overheat, affecting performance and reliability and may increase the risk of fire. ● Do not place or stack heavy items on the product. Failure to observe this precaution may result in damage to the product and other property and may lead to the risk of personal injury. ● Do not exceed ratings of outlet and wiring devices. Exceeding the rating of an outlet may increase the risk of fire and electric shock.
 <p>No wet hands</p>	<ul style="list-style-type: none"> ● Do not handle power plug with wet hands. Failure to observe this precaution may increase the risk of electrical shock.
 <p>Instruction</p>	<ul style="list-style-type: none"> ● Use and store the product within the specified temperature/humidity range. If the product is used outside the specified range for temperature and humidity continuously, it may increase the risk of fire or electric shock. ● Do not place the product at elevations of 1.24 mi. (2,000 m) or higher above sea level. Failure to do so may shorten the life of the internal parts and result in malfunctions. ● When mounting the product into the rack, provide sufficient cooling space. Mount the product in a rack meeting EIA standards, and maintain spaces above and below for air circulation. For your safety as required, attach an L-shaped bracket in addition to the panel mount bracket kit to improve mechanical stability. ● Never insert screws without the rubber feet into the threaded holes on the bottom of the product. Never insert screws without the rubber feet into the threaded holes on the bottom of the product. Doing so may lead to damage when the screws contact electrical circuitry or components inside the product. Reinstall the originally supplied rubber feet using only the originally supplied screws.

Caution

■ For operating products:





 <p>Hot surfaces Caution</p>	<ul style="list-style-type: none"> ● Do not touch the product's hot surface. <p>If the product is installed without enough space, it may cause failures of other products operation. If you touch product's hot surface, it may cause burn.</p>
 <p>Prohibited</p>	<ul style="list-style-type: none"> ● Use only the supplied power cable and AC adapter. ● Do not use the supplied power cable and AC adapter with other products. <p>If non-compliant adapter or power cables are used, it may increase the risk of fire or electrical shock.</p>
 <p>Unplug</p>	<ul style="list-style-type: none"> ● If the product won't be used for an extended period of time, unplug it. <p>Failure to observe this precaution may increase the risk of fire.</p> <ul style="list-style-type: none"> ● Unplug the product before cleaning. <p>To prevent electric shock.</p>
 <p>Instruction</p>	<ul style="list-style-type: none"> ● If cooling fan stops, power off the product and contact us. <p>Failure to do so may rise internal temperature and increase the risk of malfunction, fire, or electric shock.</p> <ul style="list-style-type: none"> ● Clean the vent holes regularly. <p>If the vent holes of the cooling fan is covered in dust, internal temperature rises and it may increase the risk of malfunction, fire, or electric shock.</p>

Table of Contents

1	Included items.....	12
2	Product outline.....	13
2.1	HDC-TR121UHD.....	13
2.2	HDC-TH221UHD/HDC-TH421UHD.....	14
2.3	HDC-RH221UHD/HDC-RH421UHD.....	15
3	Features.....	16
4	Panels.....	20
4.1	Front/side panels.....	20
4.2	Rear panel.....	21
5	System Configuration Example.....	23
6	Precautions.....	25
6.1	Attaching Rubber feet.....	25
6.2	Installation.....	25
6.3	Connection details.....	25
6.3.1	Cables.....	26
6.3.2	Securing HDMI cable.....	26
6.3.3	Category cable for extension.....	27
6.3.4	Connecting audio cable.....	28
6.3.5	Connecting RS-232C cable.....	28
6.4	Connecting LAN cable.....	29
6.5	DIN plug AC adapter with locking mechanism.....	30
7	Basic Operation.....	32
7.1	Selecting input channels.....	32
7.2	Menu operation.....	33
7.3	Control from WEB browser.....	34
7.3.1	WEB browser.....	36
7.4	Front panel security lockout.....	37
7.5	Initialization.....	37
8	Advanced Features.....	38
8.1	Downconversion.....	38
8.2	Input channel automatic switching.....	39
8.3	LAN.....	40
8.3.1	LAN loop problem through HDBaseT.....	40
8.4	RS-232C transmission.....	42
9	Menu.....	44
9.1	Front menu.....	45
9.2	WEB browser menu.....	47
9.3	Setting input switching.....	49
9.3.1	Automatic input channel switching.....	49
9.3.2	Ignoring duration after automatic switching.....	50
9.4	EDID.....	51
9.4.1	Copying EDID.....	52
9.4.2	Resolution.....	53
9.4.3	External EDID.....	56
9.4.4	Selecting copied EDID.....	57
9.4.5	Deep Color.....	58
9.4.6	LPCM audio.....	58

9.4.7	Dolby Digital audio	59
9.4.8	AAC audio	59
9.4.9	Dolby Digital Plus audio	60
9.4.10	DTS audio	60
9.4.11	DTS-HD audio	61
9.4.12	Dolby TrueHD audio	61
9.4.13	Speaker configuration	62
9.4.14	Copying EDID's CEC physical address	63
9.4.15	Input video frequency	63
9.5	Setting audio	64
9.5.1	Outputting audio	64
9.6	Configuring HDC	65
9.6.1	Grouping front panel security lockout	65
9.6.2	Alarm	66
9.6.3	Version	66
9.6.4	Displaying/Hiding menu	67
9.7	Setting input	68
9.7.1	HDCP input enabled/disabled	68
9.7.2	No-signal input monitoring	69
9.7.3	HDBaseT input long reach mode	70
9.8	Setting output	71
9.8.1	Hot plug ignoring duration	71
9.8.2	Sink device EDID check	72
9.8.3	Output format	73
9.8.4	Downconversion output	74
9.8.5	HDBaseT output long reach mode	74
9.9	Setting RS-232C	75
9.9.1	RS-232C communication	75
9.9.2	RS-232C operation mode	76
9.9.3	RS-232C sending channel	77
9.9.4	RS-232C receiving channel	78
9.10	Setting LAN	79
9.10.1	IP address	79
9.10.2	Subnet mask	80
9.10.3	TCP port number	81
9.10.4	MAC address	82
9.10.5	Setting HDBaseT LAN	82
9.11	Status indication	83
9.11.1	Viewing input information	83
9.11.2	Viewing output information	87
9.11.3	Viewing system status	91
9.12	Operations only settable from WEB menu	92
9.12.1	Editing channel name	92
9.12.2	Automatic updating time	92
9.12.3	Saving/Restoring all settings	92
9.12.4	Initialization	92
10	Product specification	93
10.1	HDC-TR121UHD	93
10.2	HDC-TH221UHD/HDC-TH421UHD	95
10.3	HDC-RH221UHD/HDC-RH421UHD	97

11 Troubleshooting 99

1 Included items

Ensure that all items illustrated below are included in the package.

If any items are missing or damaged, please contact IDK.

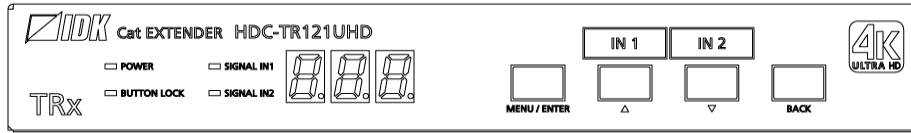

One (1) main unit (Example: HDC-TR121UHD)

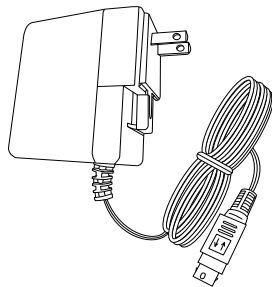

DIN plug AC adapter with locking mechanism (3.9 ft. (1.2 m))

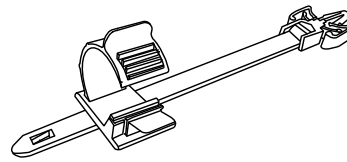

Cable clamps:

- Two (2) for HDC-TR121UHD
- Two (2) for HDC-TH221UHD
- Two (2) for HDC-TH421UHD
- Three (3) for HDC-RH221UHD
- Five (5) HDC-RH421UHD

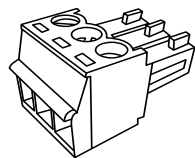

Two (2) 3-pin captive screw connectors

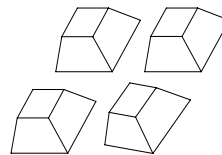

Four (4) Rubber feet

[Fig. 1.1] Included items

2 Product outline

The HDC-UHD series products are two-input extenders with EDID emulator for sending HDMI, DVI, and HDBaseT input signals at up to 4K@60 over a Category cable without compression or processing. Input video signals are converted to HDBaseT format and can be transmitted up to 100 m (328 ft.); 1080p (24 bit) video signals can be sent up to 150 m (492 ft.) in Long reach mode.

2.1 HDC-TR121UHD

The HDC-TH221UHD/HDC-TH421UHD includes one HDMI output and one HDBaseT output. The HDMI OUT1 enables down conversion that outputs 4K input video at 1080p automatically depending on sink device status. The video inputs can be controlled by the front panel or an external controller.

The HDC-TR121UHD also features Daisy chain for extending and distributing video, audio, and control signals. In addition, digital audio signals can be de-embedded onto the analog output signals. It supports bidirectional RS-232C and LAN communication.

All connected HDC-UHD products can be monitored through WEB browser for troubleshooting.

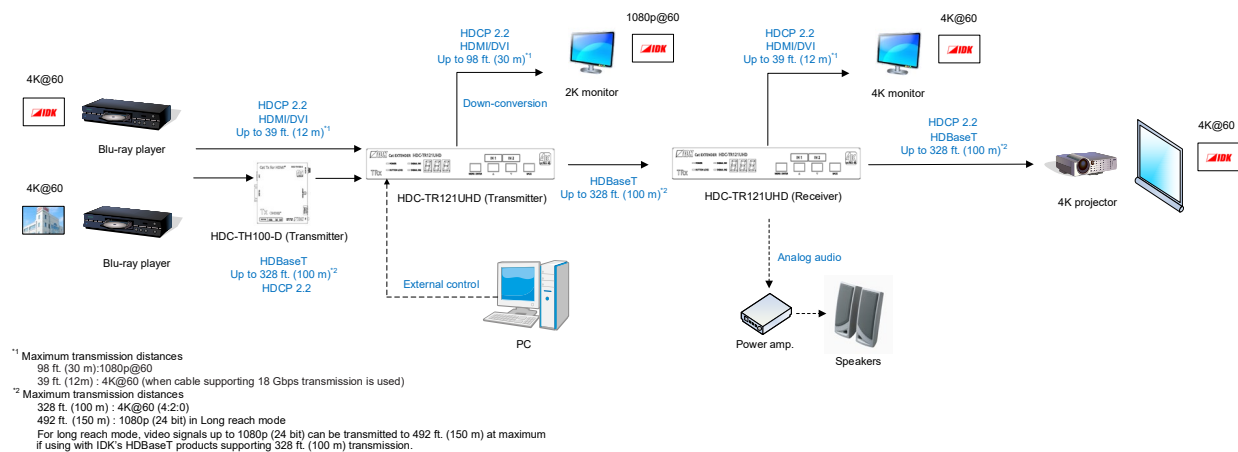

[Fig. 2.1] Application example (HDC-TR121UHD)

2.2 HDC-TH221UHD/HDC-TH421UHD

The HDC-TH221UHD/HDC-TH421UHD includes one HDMI output and two/four HDBaseT outputs. The HDMI OUT1 enables down conversion that outputs 4K input video at 1080p automatically depending on sink device status. The video inputs can be controlled by the front panel or an external controller.

The HDC-TH221UHD/HDC-TH421UHD also features Daisy chain for extending and distributing video, audio, and control signals. In addition, digital audio signals can be de-embedded onto the analog output signals. It supports bidirectional RS-232C and LAN communication.

All connected HDC-UHD products can be monitored through WEB browser for troubleshooting.

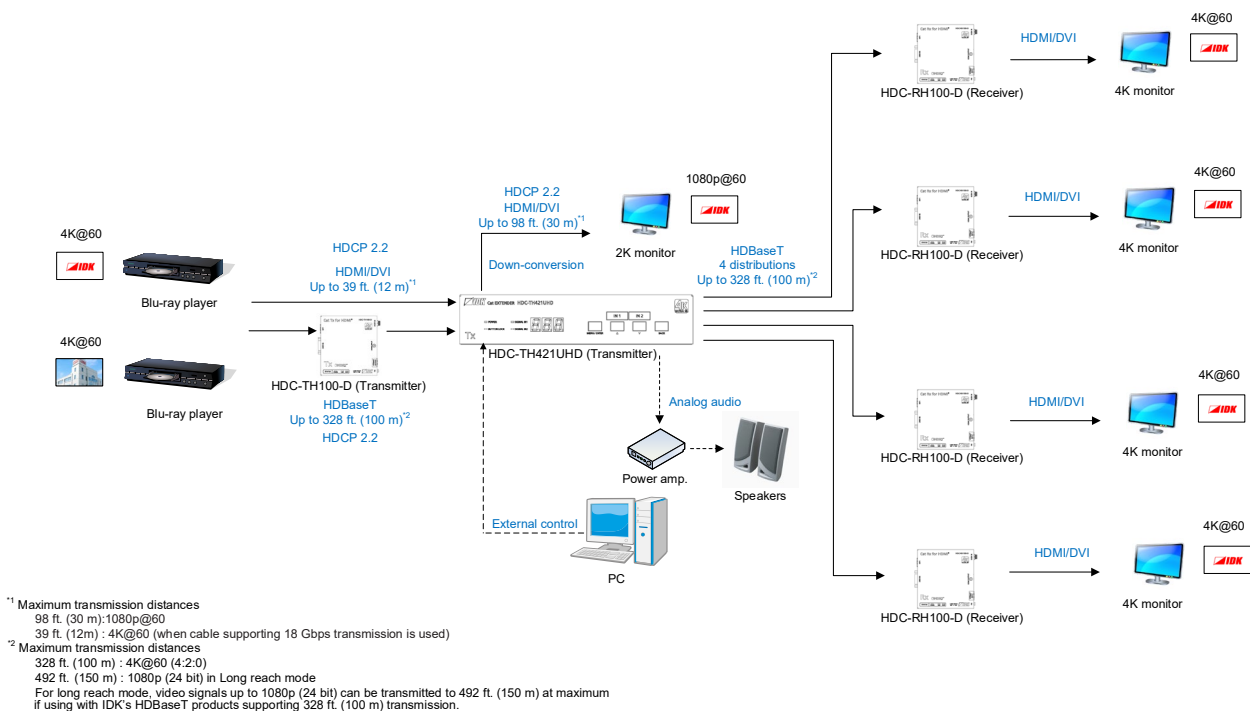

[Fig. 2.2] Application example (HDC-TH421UHD)

2.3 HDC-RH221UHD/HDC-RH421UHD

The HDC-RH221UHD/HDC-RH421UHD includes two/four HDMI outputs and one HDBaseT output. The HDMI OUT1 enables down conversion that outputs 4K input video at 1080p automatically depending on sink device status. The two video inputs can be controlled by the front panel or an external controller.

The HDC-RH221UHD/HDC-RH421UHD also features Daisy chain for extending and distributing video, audio, and control signals. In addition, digital audio signals can be de-embedded onto the analog output signals. It supports bidirectional RS-232C and LAN communication.

All connected HDC-UHD products can be monitored through WEB browser for troubleshooting.

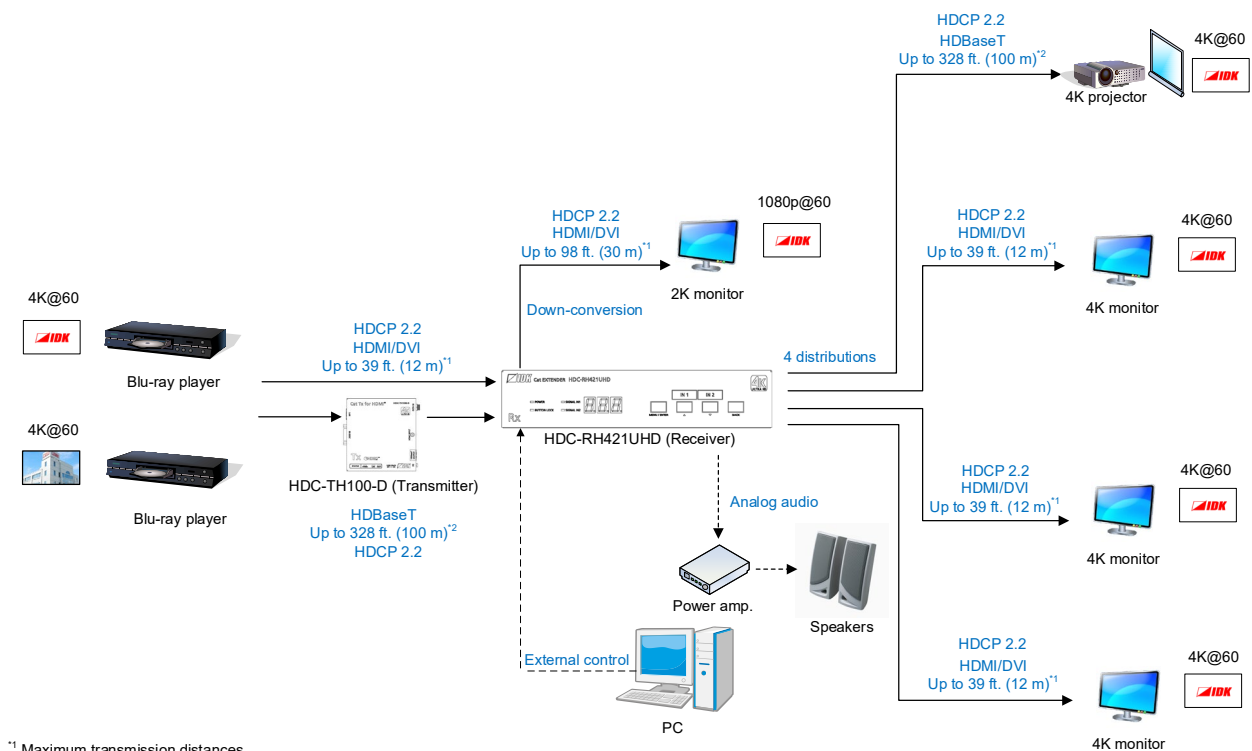

¹ Maximum transmission distances
 98 ft. (30 m): 1080p@60
 39 ft. (12m) : 4K@60 (when cable supporting 18 Gbps transmission is used)

² Maximum transmission distances
 328 ft. (100 m) : 4K@60 (4:2:0)
 492 ft. (150 m) : 1080p (24 bit) in Long reach mode
 For long reach mode, video signals up to 1080p (24 bit) can be transmitted to 492 ft. (150 m) at maximum if using with IDK's HDBaseT products supporting 328 ft. (100 m) transmission.

[Fig. 2.3] Application example (HDC-RH421UHD)

3 Features

■ Video

- Up to 4K@60 (4: 4: 4)
- HDCP 1.4/2.2
- HDR
- 3D
- x.v.Color
- Up to 328 ft. (100 m) 4K@60 over CAT.5E HDC/Cat5e STP/Cat6 STP cable
- Transmission over Cat5e UTP cable^{*1}
- Up to 328 ft. (100 m) over Cat6 UTP cable^{*2}
- Up to 492 ft. (150 m) in Long reach mode (1080p 60 Hz 24 bit or less)^{*3}
- HDMI Transmission distances:
 - Up to 98 ft. (30 m) : 1080p@60
 - Up to 39 ft. (12 m) : 4K@60 (when cable supporting 18 Gbps transmission is used)
- No virtual delay (10 μ s or less/328 ft. (100 m))
- OUT1 supports down conversion (4K to 1080p)
- Daisy chain connection
- Anti-snow

■ Audio

- De-embedding

■ Communication

- Point-to-point (bidirectional) and point-to-multipoint (unidirectional) RS-232C communication
- LAN

■ Others

- EDID emulation
- WEB browser control
- Input channel automatic switching
- CEC (Pass-through)
- Connection Reset
- Front panel security lockout
- HDBaseT: RS-232C and LAN are supported
- AC adapter with locking mechanism

^{*1} If exceeding 164 ft. (50 m), CAT.5E HDC, Cat5e STP, and Cat6 UTP/STP cables are recommended.

^{*2} If the 4K format exceeds 230 ft. (70 m), CAT.5E HDC, Cat5e STP, and Cat6 STP cables are recommended.

^{*3} If exceeding 328 ft. (100 m) in Long reach mode, CAT.5E HDC, Cat5e STP, and Cat6 STP cables are recommended.

■ Diagrams

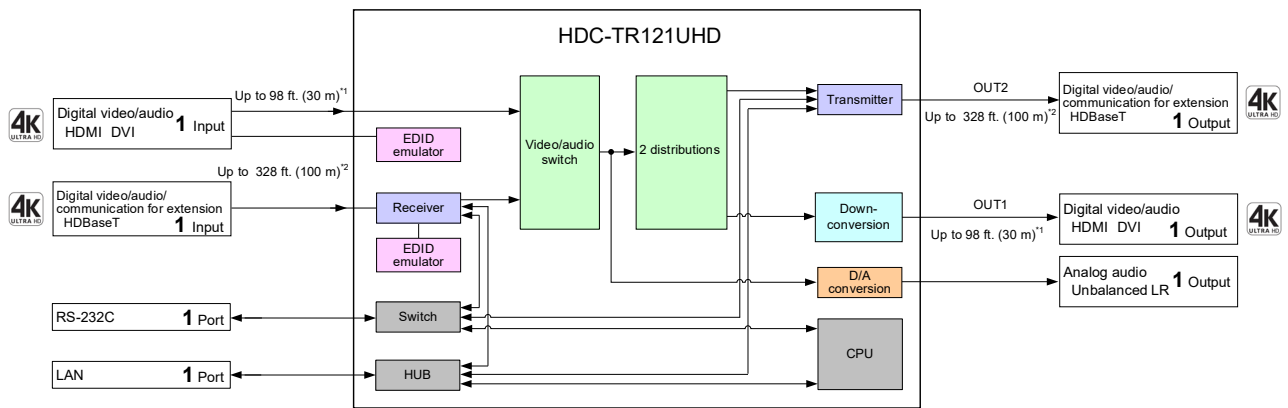

¹ Maximum transmission distances
 98 ft. (30 m): 1080p@60
 39 ft. (12m) : 4K@60 (when cable supporting 18 Gbps transmission is used)

² Maximum transmission distances
 328 ft. (100 m) : 4K@60 (4:2:0)
 492 ft. (150 m) : 1080p (24 bit) in Long reach mode
 For long reach mode, video signals up to 1080p (24 bit) can be transmitted to 492 ft. (150 m) at maximum if using with IDK's HDBaseT products supporting 328 ft. (100 m) transmission.

[Fig. 3.1] HDC-TR121UHD diagram

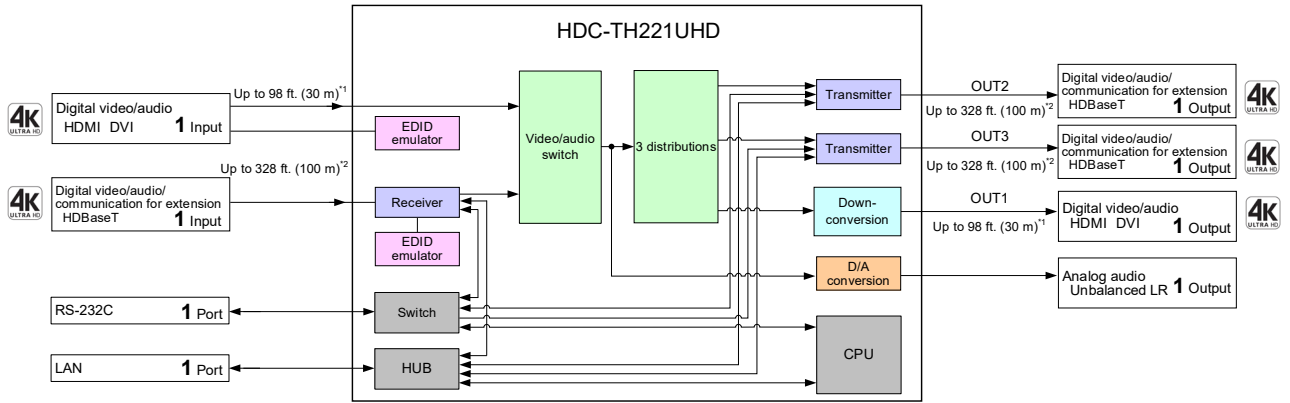

¹ Maximum transmission distances
 98 ft. (30 m):1080p@60
 39 ft. (12m) : 4K@60 (when cable supporting 18 Gbps transmission is used)

² Maximum transmission distances
 328 ft. (100 m) : 4K@60 (4:2:0)
 492 ft. (150 m) : 1080p (24 bit) in Long reach mode
 For long reach mode, video signals up to 1080p (24 bit) can be transmitted to 492 ft. (150 m) at maximum if using with IDK's HDBaseT products supporting 328 ft. (100 m) transmission.

[Fig. 3.2] HDC-TH221UHD diagram

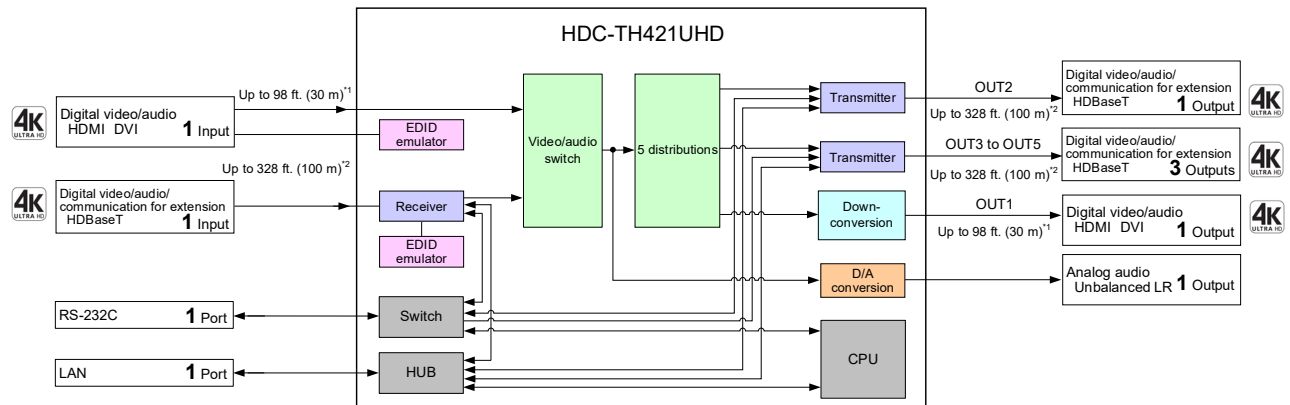

¹ Maximum transmission distances
 98 ft. (30 m):1080p@60
 39 ft. (12m) : 4K@60 (when cable supporting 18 Gbps transmission is used)

² Maximum transmission distances
 328 ft. (100 m) : 4K@60 (4:2:0)
 492 ft. (150 m) : 1080p (24 bit) in Long reach mode
 For long reach mode, video signals up to 1080p (24 bit) can be transmitted to 492 ft. (150 m) at maximum if using with IDK's HDBaseT products supporting 328 ft. (100 m) transmission.

[Fig. 3.3] HDC-TH421UHD diagram

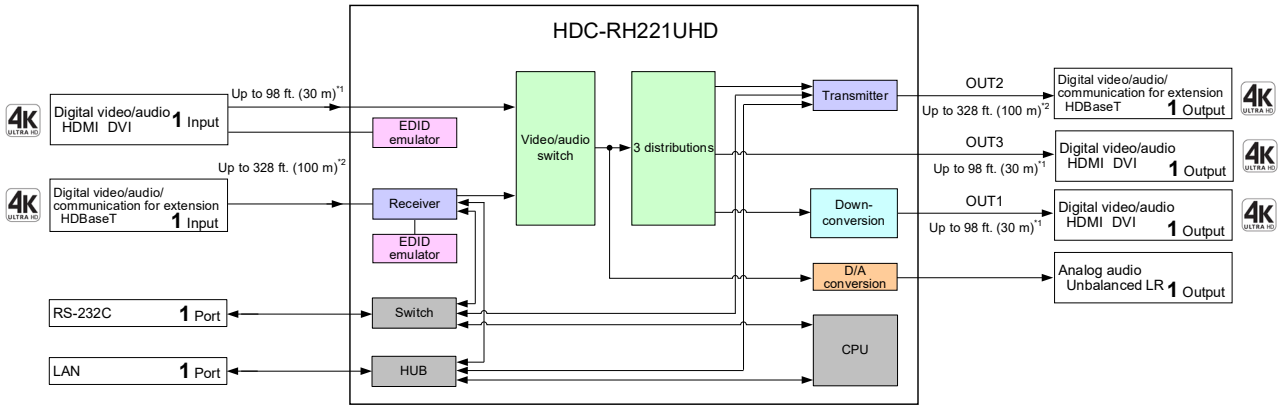

¹ Maximum transmission distances
 98 ft. (30 m):1080p@60
 39 ft. (12m) : 4K@60 (when cable supporting 18 Gbps transmission is used)

² Maximum transmission distances
 328 ft. (100 m) : 4K@60 (4:2:0)
 492 ft. (150 m) : 1080p (24 bit) in Long reach mode
 For long reach mode, video signals up to 1080p (24 bit) can be transmitted to 492 ft. (150 m) at maximum if using with IDK's HDBaseT products supporting 328 ft. (100 m) transmission.

[Fig. 3.4] HDC-RH221UHD diagram

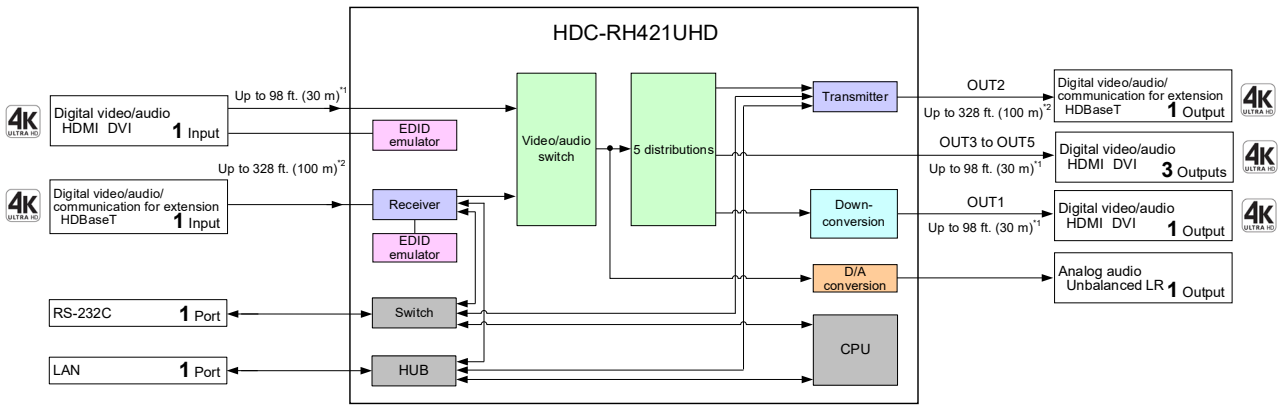

¹ Maximum transmission distances
 98 ft. (30 m):1080p@60
 39 ft. (12m) : 4K@60 (when cable supporting 18 Gbps transmission is used)

² Maximum transmission distances
 328 ft. (100 m) : 4K@60 (4:2:0)
 492 ft. (150 m) : 1080p (24 bit) in Long reach mode
 For long reach mode, video signals up to 1080p (24 bit) can be transmitted to 492 ft. (150 m) at maximum if using with IDK's HDBaseT products supporting 328 ft. (100 m) transmission.

[Fig. 3.5] HDC-RH421UHD diagram

4 Panels

4.1 Front/side panels

● Front panel

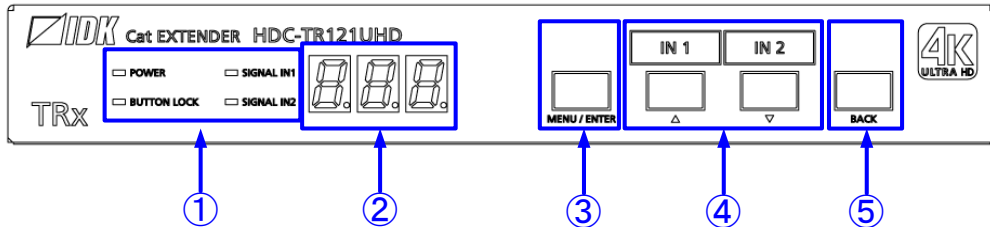

● Side panels

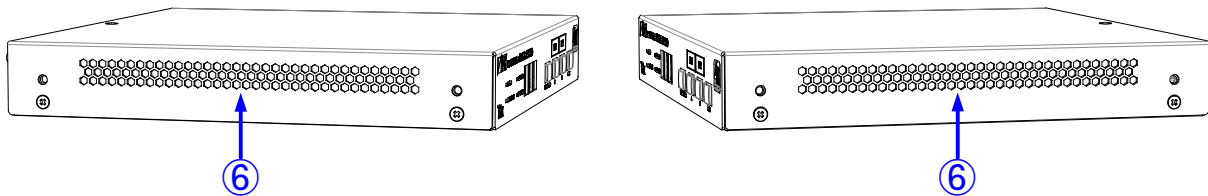

[Fig. 4.1] Front/side panel drawings (HDC-TR121UHD)

[Table 4.1] Front/side panel features

#	Feature	Description
①	LED indicators	<ul style="list-style-type: none"> POWER : Lights when power is supplied from the AC adapter. BUTTON LOCK : Lights when the MENU/ENTER button is locked 【See: 7.4 Front panel security lockout】 SIGNAL IN1/IN2 : Lights when video signal is input. Does not light when no video signal is input.
②	7-Segment display	<p>Top page : Displays the selected channel. After 30 seconds of menu operation buttons* inactivity, the 7-segment display is turned off.</p> <p>Menu page: Displays menu number, setting number, settings, or other values related to the menu. After 60 seconds of menu operation buttons* inactivity, it goes back to the top page.</p>
③	MENU/ENTER button	Enters menu and selects options.
④	Input channel selection buttons	<p>Top screen : Selects a channel. The button of the selected channel lights.</p> <p>Menu page : Selects a menu and setting.</p>
⑤	BACK button	Available only in menu page. Goes back to the previous page.
⑥	Ventilation holes	Prevents internal temperature raise. Do not block ventilation holes.

*Menu operation buttons: ③, ⑤, and ④ in the menu page.

4.2 Rear panel

HDC-TR121UHD

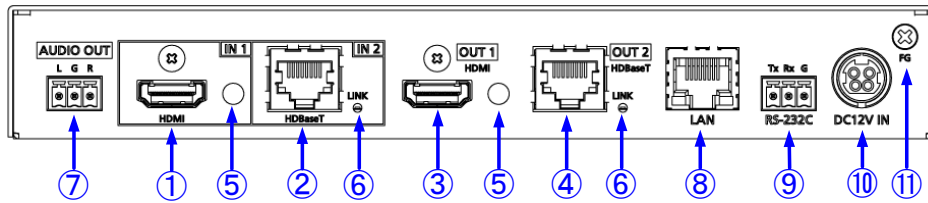

HDC-TH221UHD

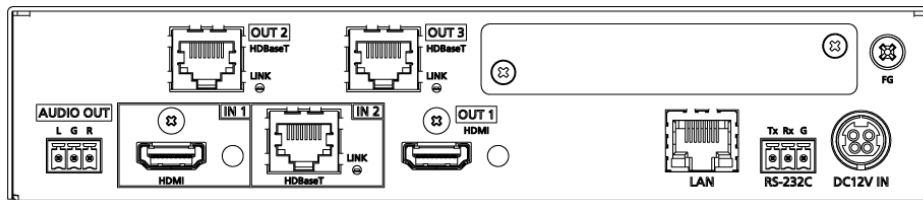

HDC-TH421UHD

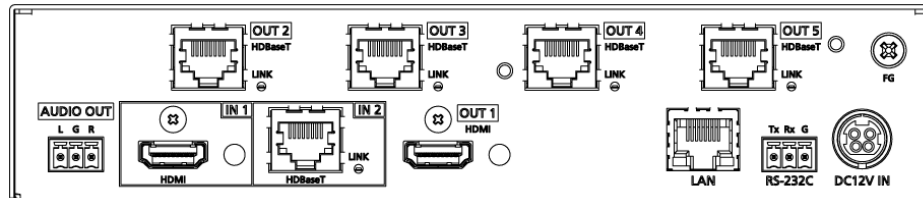

HDC-RH221UHD

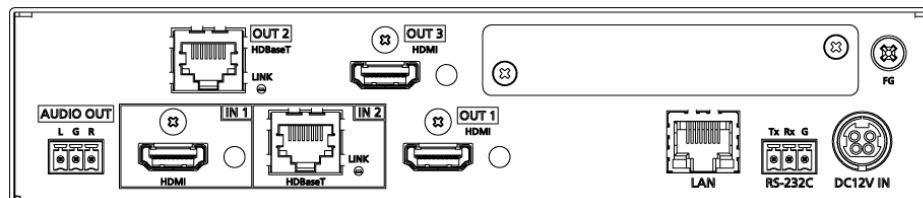

HDC-RH421UHD

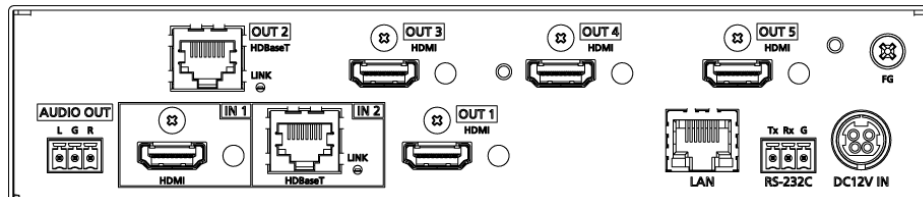

[Fig. 4.2] Rear panel drawings

[Table 4.2] Rear panel features

#	Feature	Description
①	HDMI input connector	Input connector for HDMI and DVI signals to interface source devices, such as Blu-ray player and PC.
②	HDBaseT input connector	Input connector for HDBaseT signal Connects to a transmitter over a category cable. 【See: 9.7.3 HDBaseT input long reach mode】
③	HDMI output connectors	Output connectors for HDMI and DVI signals, interfaces sink devices such as LC monitors and projectors.
④	HDBaseT output connectors	Output connector for HDBaseT signal Connects to a receiver over a category cable. 【See: 9.8.5 HDBaseT output long reach mode】
⑤	HDMI cable fixing holes	Retain HDMI cables by inserting cable clamps. 【See: 6.3.2 Securing HDMI cable】
⑥	HDBaseT LINK LED	Lights when an HDC series or HDBaseT supported product is connected Blinks every 0.5 seconds when the connected device is in standby state. In standby state, LAN and RS-232C communication is still available. Does not light when no HDC series or HDBaseT supported product is connected.
⑦	Analog audio output connectors	3-pin captive screw analog audio output connector interfaces amplifiers, speakers, and mixers. 【See: 6.3.4 Connecting audio cable】
⑧	LAN connector	For external control by communication commands or web browsers 【See: 6.3.5 Connecting RS-232C cable】
⑨	RS-232C connector	3-pin captive screw connector for RS-232C serial control. 【See: 6.3.5 Connecting RS-232C cable】
⑩	Power supply connector	For use with supplied AC adapter.
⑪	Frame ground	For bonding chassis to local ground. HDC-TR121UHD: An M3 screw is used. HDC-TH221UHD, HDC-TH421UHD, HDC-RH221UHD, and HDC-RH421UHD: An M4 screw is used.

5 System Configuration Example

Application example: Source and sink devices are connected to the HDC.

■ Daisy Chain connection

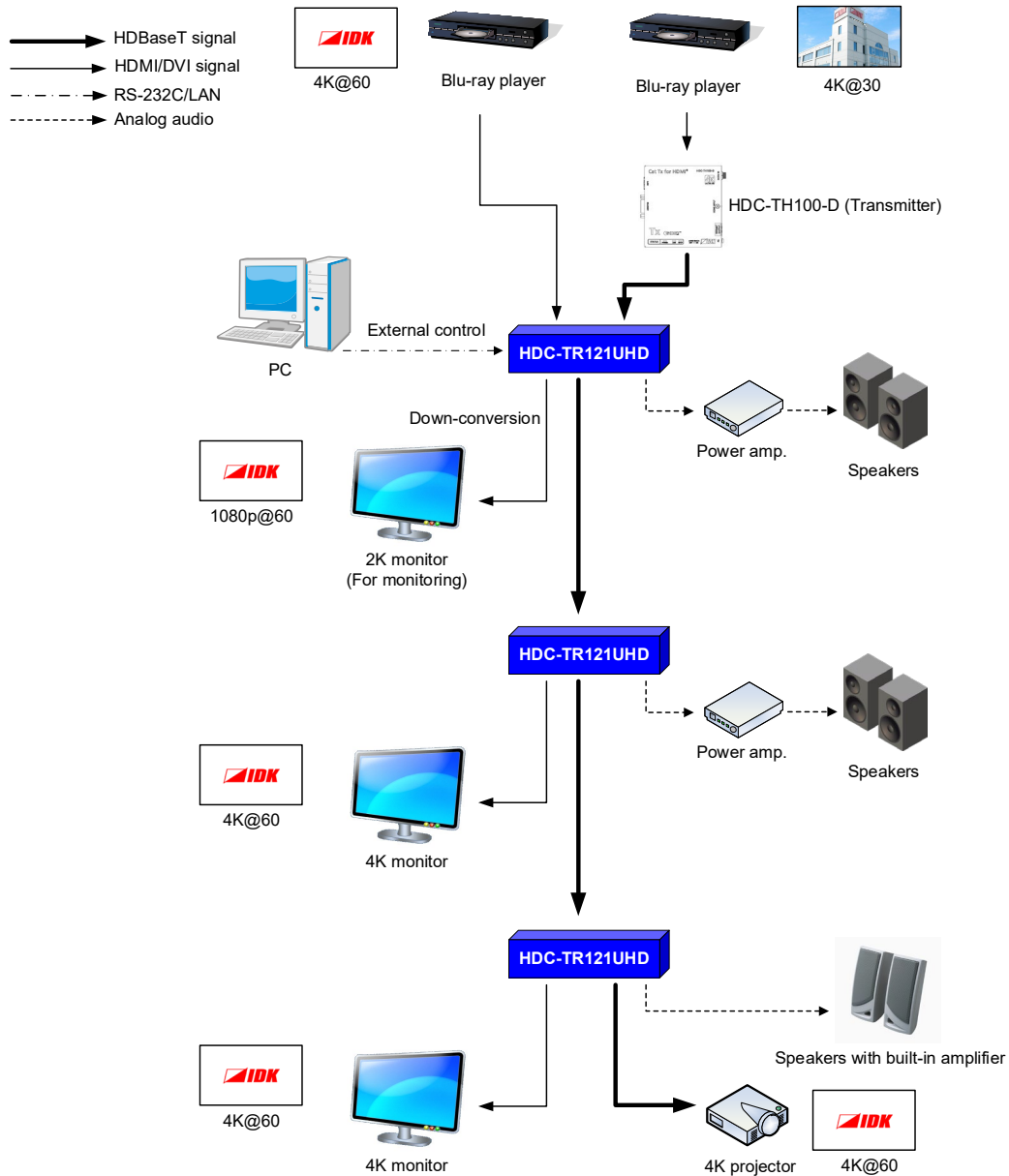

[Fig. 5.1] Application example (HDC-TR121UHD)

■ Cascade connection

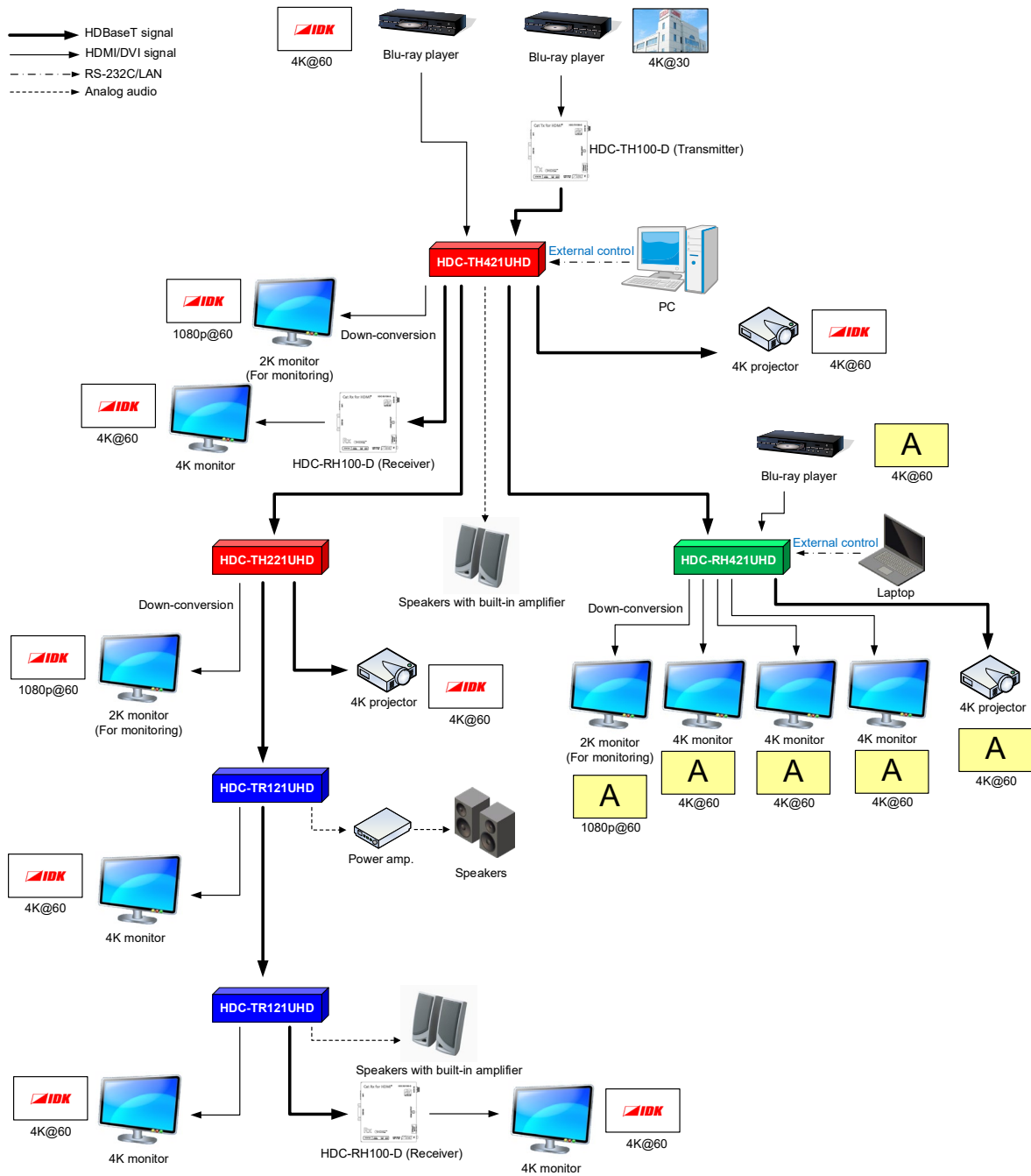

[Fig. 5.2] Application example

(using HDC-TH421UHD, HDC-RH421UHD, HDC-TH221UHD, and HDC-TR121UHD)

6 Precautions

Before connecting to external devices, follow the precautions below.

6.1 Attaching Rubber feet

First, clean the bottom, surface of the HDC as needed, and then peel the release papers from the rubber feet and place them in each of the four corners.

6.2 Installation

When installing the HDC, observe the following precautions; otherwise, the internal temperature increases and it may affect the product lifetime and operation.

- Do not stack or place one HDC directly on top of another HDC. The internal temperature increases when 4K signals are transmitted.
- Do not block vent holes.
- To provide adequate ventilation, maintain sufficient clearances around the HDC (1.2 in. (30 mm) or more).
- Consider installing the HDC in an environment compatible with the maximum temperature indicated in the specification sheet 32°F to 104°F (0°C to +40°C).

Tip:

For installing the HDC in an EIA rack, we offer optional rack mounting hardware. Please contact us as needed.

6.3 Connection details

When connecting the HDC to external devices, observe the following precautions.

- Read manuals for the external devices.
- Before connecting cables to the HDC or an external device, dissipate static electricity by touching grounded metal such as equipment racks before handling signal cables. Failure to observe this precaution may result in ESD (electrostatic discharge) damage.
- Power all units off before connecting cables.
- Be sure to fully seat all plugs and connections and dress cables to reduce stress on connectors.

6.3.1 Cables

Use the correct HDMI cable or HDMI-DVI conversion cable depending on the system configuration. For analog audio, select or fabricate cables to match the connectors as needed.

For 4K format video, the maximum TMDS data rate (transmission speed) is 18 Gbps. If a high-speed HDMI cable that supports up to 10.2 Gbps rate is used, video cannot be displayed stably. Select an appropriate 18 Gbps high-speed cable depending on the 4K format.

The maximum distance may change depending on cable type and characteristics of source and sink devices.

[Table 6.1] 18 Gbps high-speed cable for 4 K format

4K format	TMDS data rate (Gbps)								
	RGB, YCbCr 4:4:4			YCbCr 4:2:2			YCbCr 4:2:0		
	24 bit	30 bit	36 bit	24 bit	30 bit	36 bit	24 bit	30 bit	36 bit
3840x2160p (24/25/30)	10.2 Gbps	18 Gbps	18 Gbps	10.2 Gbps	10.2 Gbps	10.2 Gbps	N/A	N/A	N/A
4096x2160 (24/25/30)	10.2 Gbps	18 Gbps	18 Gbps	10.2 Gbps	10.2 Gbps	10.2 Gbps	N/A	N/A	N/A
3840x2160p (50/59.94/60)	18 Gbps	N/A	N/A	18 Gbps	18 Gbps	18 Gbps	10.2 Gbps	18 Gbps	18 Gbps
4096x2160 (50/59.94/60)	18 Gbps	N/A	N/A	18 Gbps	18 Gbps	18 Gbps	10.2 Gbps	18 Gbps	18 Gbps

18 Gbps: 18 Gbps high-speed cable; 10.2 Gbps: 10.2 Gbps cable

Note:

If a cable is extended and a cable joint (JJ) is used, video may be interrupted or may not be output.

6.3.2 Securing HDMI cable

Secure HDMI cables using cable clamps to prevent connectors from being accidentally pulled out of ports.

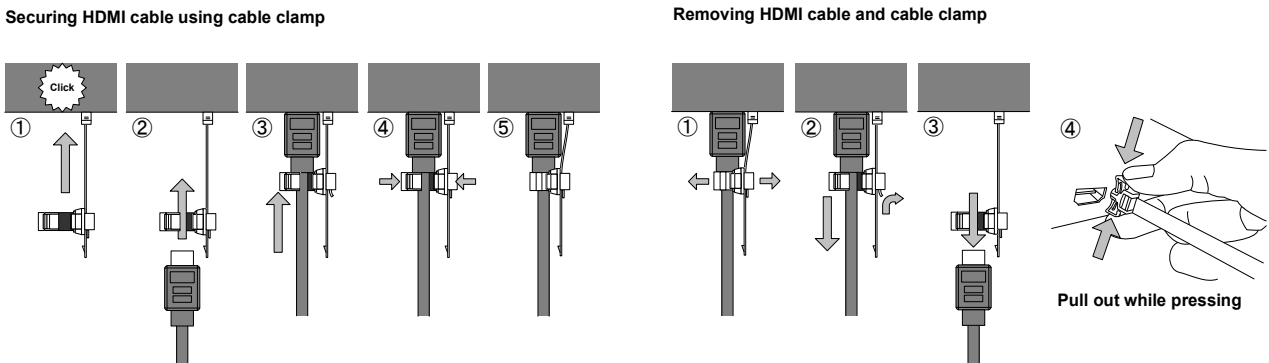

[Fig. 6.1] Securing and removing cable clamp

6.3.3 Category cable for extension

To ensure the best performance with category cables, select a high quality category cable type, ensuring that proper pinning and pairing requirements are observed.

- Cat5e UTP/STP and Cat6 UTP/STP can be used, but we recommend CAT.5E HDC cable* for optimal performance.
- If using STP cables, connect the FG connector to a local electrical ground bonding point. Without bonding FG to ground, the shielding feature may not effectively eliminate interference. If using UTP cables, it is still recommend that the FG connector be used.
- The STP cables are less affected by interference or external noise than UTP cables.
- Connectors for long-haul transmission are the same as that of eight-core modular connector used for Ethernet, but the transmission system is not the same so that it cannot be connected to Ethernet.
- The maximum transmission distance of a category cables is the shorter distance of the maximum transmission distances of transmitter/receiver/sink device connected to the HDC.
- Pin assignments: T568A or T568B straight
- Do not pull the cable using excessive force. The allowable tension of the category cable is 110 N.
- Do not bend the cable at a sharp angle. Keep the bend radius four times of the cable diameter or larger.
- Do not clamp or tie the cable tightly; leave some space allowing the cable to move slightly.
- If you use multiple category cables, we recommend keeping a distance between the cables or not to place the cables closely in parallel.
- Keep the category cable running as straight as possible. Looping or coiling the cable, causes it to be more easily affected by noise; especially when using longer cable run lengths.
- Do not place the cable in an electrically noisy environment, since high-speed impulsive noise may couple into the category cable. Use of a high-output radio transmission device near the HDC or remote receivers may interfere with or interrupt video and or audio signals.
- If the total transmission distance from the transmitter to receiver is 328 ft. (100 m) or less, up to two cable interconnection points can be used. Products supporting Cat6A (10GBase-T) are recommended. The maximum transmission distance of high-resolution transmission, such as 4K, may be shortened by about 10% compared with other lower bandwidth resolution formats.
- The table below shows supported transmission distance for each category.
Note that specified distances may shorten depending on the conditions within the actual environment.

[Table 6.2] Transmission distance

Noise influence	Category		Transmission distance	TMDS clock	Recommended cable
Easily affected	UTP	Cat5e	164 ft. (50 m)	\leq 225 MHz	For 164 ft. (50 m) or longer: CAT.5E HDC*, Cat5e STP, and Cat6 UTP/STP cables
		Cat6	328 ft. (100 m)		
Less affected	STP	Cat5e* Cat6	328 ft. (100 m)		For 4K format 230 ft. (70 m) or longer: CAT.5E HDC*, Cat5e STP, and Cat6 STP cables

* The CAT.5E HDC cable is a double-shielded category cable optimized for video signal transmission. The double-shielded structure protects the video signal from external interference. It is certified to 500 MHz bandwidth at distances up to 328 ft. (100 m) and verified to meet requirements specified by HDBaseT Alliance.

Note:

If there is a problem in the transmission path, video or audio may be interrupted. Check the “[Table 6.2]” above.

If the problem persists, it may be necessary to shorten the category cable.

6.3.4 Connecting audio cable

Connect audio cables to the 3-pin captive screw connectors.

28 AWG to 16 AWG conductor gauge and a strip length of 0.28 in. (7 mm) are recommended.

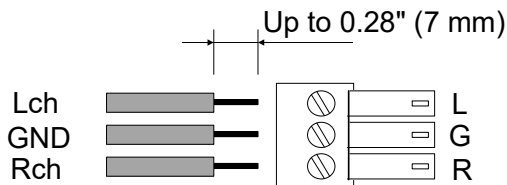

[Fig. 6.2] Connecting audio cable to 3-pin captive screw connector

6.3.5 Connecting RS-232C cable

The HDC’s RS-232C connection is supported by a 3-pin captive screw connector.

Insert and secure the wires from the RS-232C cable into the supplied 3-pin captive screw connector, and then insert the captive screw connector into the mating connector on the HDC.

28 AWG to 16 AWG conductor gauge is recommended. The recommended wire strip length is 0.28 in. (7 mm).

Short RTS/CTS and DTR/DSR as needed.

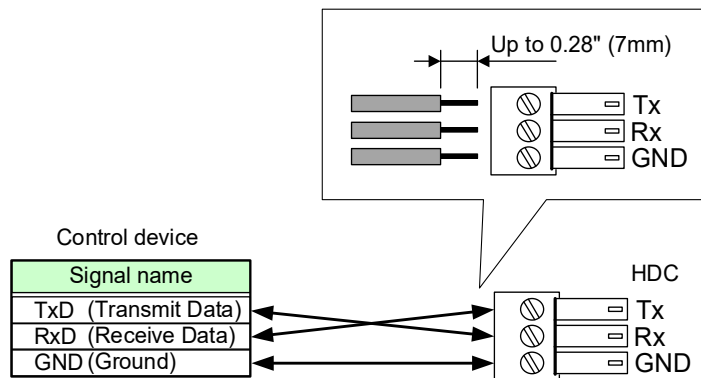

[Fig. 6.3] Connecting RS-232C cable to 3-pin captive screw connector

6.4 Connecting LAN cable

Pin assignment of the LAN connector is as follows.

Auto MDI/MDI-X that detecting and switching straight cable/cross cable is supported.

Light in orange if the send/receive rate is 100 Mbps.
Goes off if it is 10 Mbps.

Light in green while link is established.
Blinks in green while data is being sent/received.

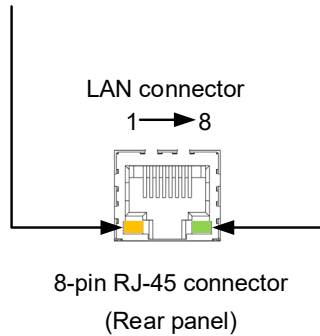

Pin#	Signal Name	
	MDI	MDI-X
1	TX+ (Transmitted Data +)	RX+ (Received Data +)
2	TX- (Transmitted Data -)	RX- (Received Data -)
3	RX+ (Received Data +)	TX+ (Transmitted Data +)
4	N.C. (Not Connected)*	N.C. (Not Connected)*
5	N.C. (Not Connected)*	N.C. (Not Connected)*
6	RX- (Received Data -)	TX- (Transmitted Data -)
7	N.C. (Not Connected)*	N.C. (Not Connected)*
8	N.C. (Not Connected)*	N.C. (Not Connected)*

*Not used

[Fig. 6.4] LAN connector

Make sure not to form a loop by the HDC when connecting a LAN cable to the HDC.

The HDC constantly send broadcast packet in order to notify status.

If adding the LAN cable to the existing network, avoid problems, such as broadcast storm caused by broadcast traffic.

Broadcast storm: This problem occurs when a network system is overwhelmed by continuous broadcast traffic or the like.

6.5 DIN plug AC adapter with locking mechanism

The shapes of AC plugs with screw locking mechanism vary from country to country. The AC plug can be removed from the AC adapter.

Removing AC plug:

Slide the AC plug (②) from the AC adapter while holding down the portion mentioned below (①)

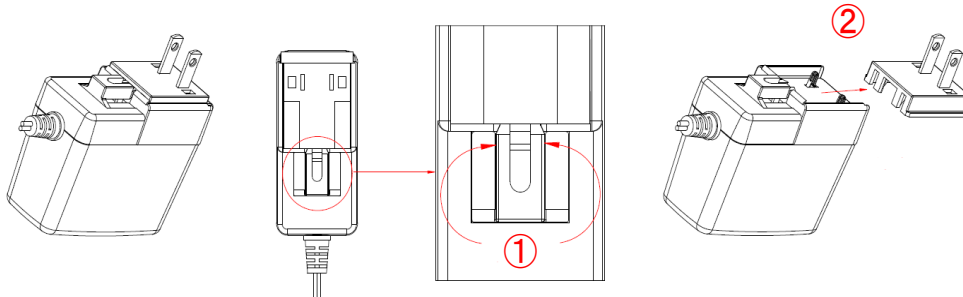

[Fig. 6.5] Removing AC plug (Example: Plug type A)

Attaching AC plug:

Gently slide the AC plug into the AC adapter (③) until it clicks (④)

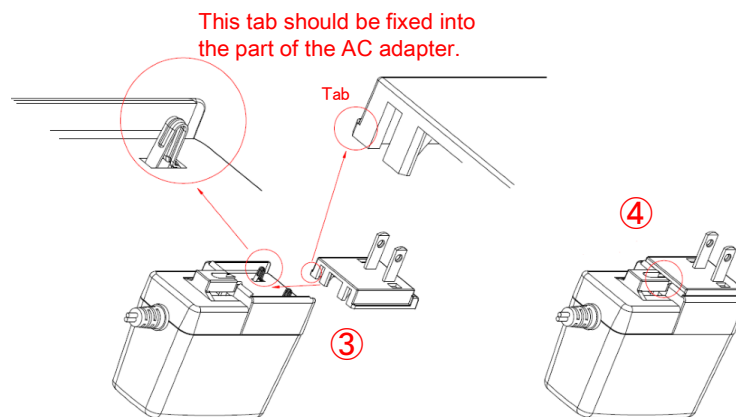

[Fig. 6.6] Attaching AC plug (Example: Plug type A)

■ Plugging and unplugging DC plug

Plug the DC plug to the power supply connector of the unit until it clicks.
Hold the portion mentioned below when unplugging the DC plug.

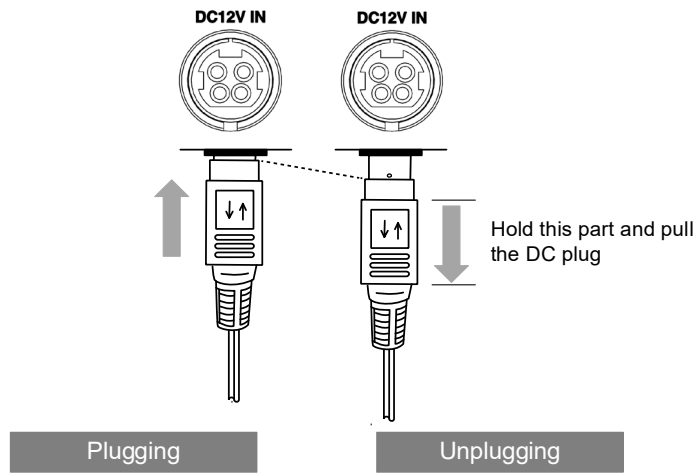

[Fig. 6.7] Plugging and unplugging DC plug

7 Basic Operation

7.1 Selecting input channels

You can switch input channel using input channel selection buttons (IN1 and IN2) in top screen.

The 7-segment LEDs show the selected input channel (“CH1” or “CH2”).

Press the “BACK” button until an input channel selection button lights in order to go back to the top menu.

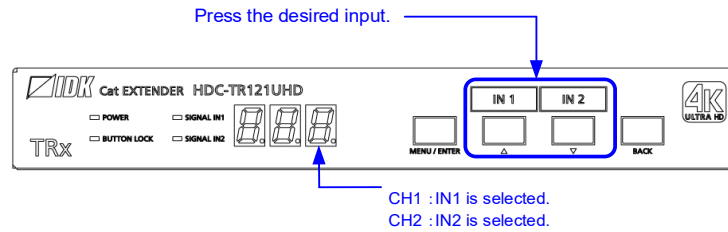

[Fig. 7.1] Selecting input channel

Tip:

Once input with HDCP is selected, the HDC keeps the output with HDCP. Switching time would be shorter because the HDCP is not needed to be re-authorized. When rebooting the HDC or unplugging and plugging the cable, HDCP authentication will be reset.

7.2 Menu operation

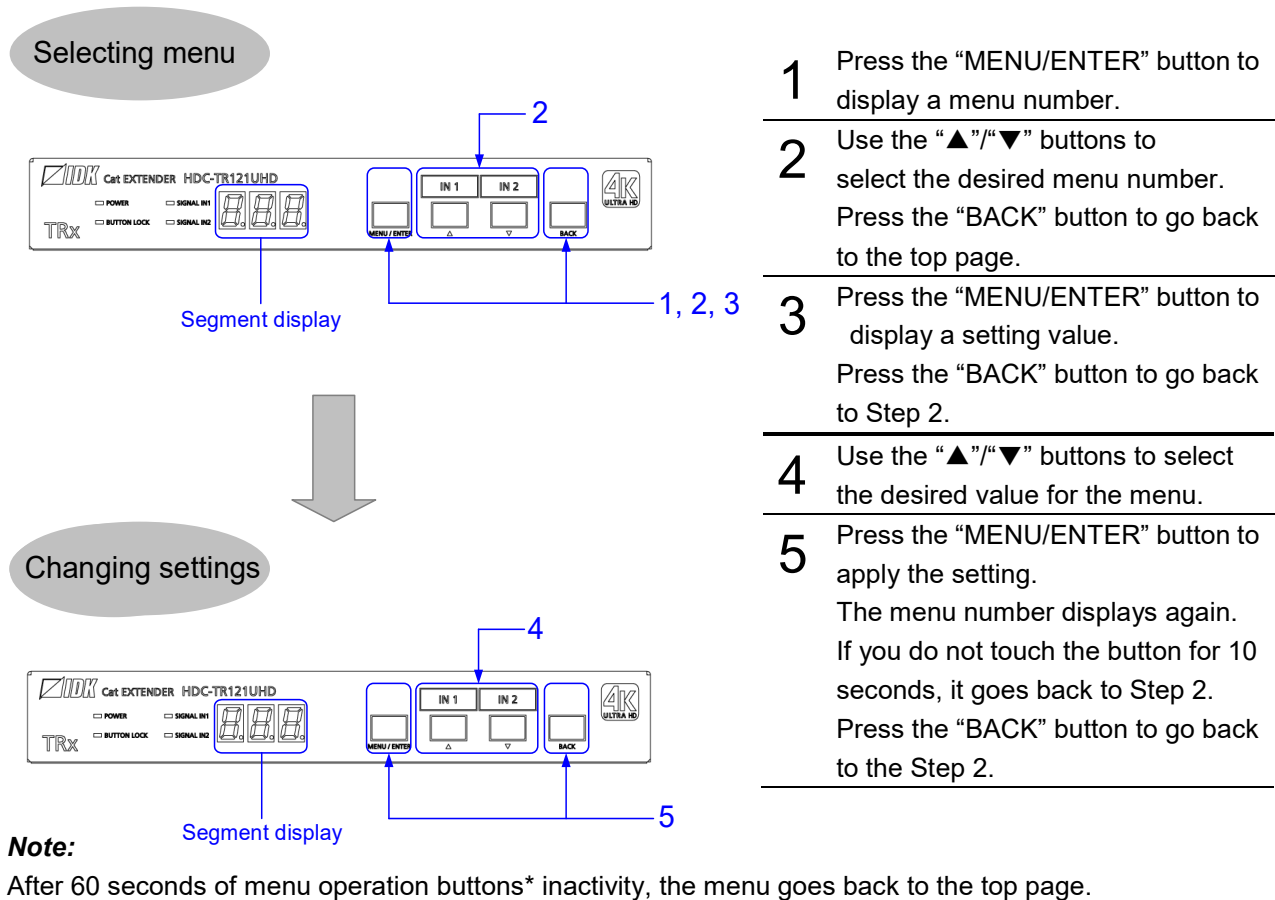

[Fig. 7.2] Setting from front buttons

7.3 Control from WEB browser

The HDC can be controlled from a WEB browser through LAN.

To open [CHANNEL WINDOW], enter the IP address of HDC in the address bar of WEB browser. The size of the [CHANNEL WINDOW] can be adjusted.

Note that the default IP address is 192.168.1.199. This default address is common among all HDC series products.

【See: 9.10.1 IP address】



[Fig. 7.3] CHANNEL WINDOW

To open the Web menu window, enter the IP address + “/menu.html” into the address bar.

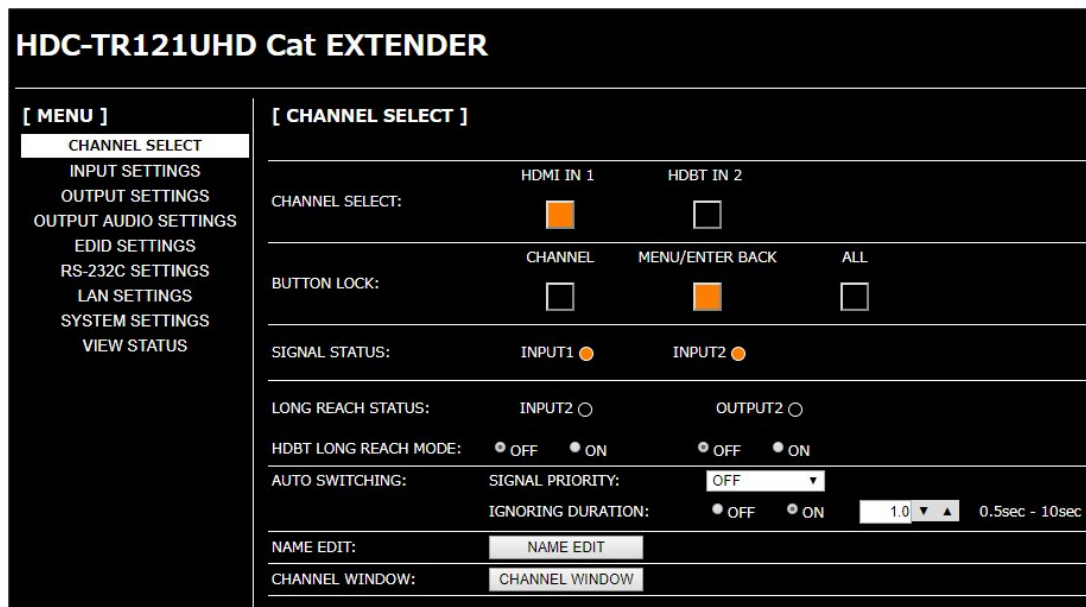

[Fig. 7.4] WEB menu

To show information of signal and connected devices, select [VIEW STATUS].

HDC-RH421UHD Cat EXTENDER					
[MENU]	[VIEW STATUS]				
CHANNEL SELECT					
INPUT SETTINGS					
OUTPUT SETTINGS					
OUTPUT AUDIO SETTINGS					
EDID SETTINGS					
RS-232C SETTINGS					
LAN SETTINGS					
SYSTEM SETTINGS					
VIEW STATUS					
[INPUT STATUS]	VIDEO STATUS	: HDMI IN 1	HD BT IN 2		
HDMI IN 1	VIDEO FORMAT	: UNSELECTED	3840x2160p 59.94Hz		
HDMI IN 2	INPUT MODE	:	HDMI MODE		
	HDCP	:	HDCP 1.4		
	COLOR SPACE	:	YCbCr 4:2:0 LIMITED RANGE YUV709		
	DEEP COLOR	:	24 BIT COLOR		
	SCRAMBLE	:	SCRAMBLE OFF		
	AUDIO STATUS	: HDMI IN 1	HD BT IN 2		
	AUDIO FORMAT	: UNSELECTED	LINEAR PCM		
	SAMPLING FREQUENCY	:	48 kHz		
	SPEAKER	:	2 CHANNEL		
	CONFIGURATION	:			
	BIT LENGTH	:	24 BIT		
[SINK DEVICE STATUS]					
HDMI OUT 1	HDCP AUTHENTICATION	: HDMI OUT 1	HD BT OUT 2	HDMI OUT 3	HDMI OUT 4
HDMI OUT 2	HDCP 1.4	: HDMI OUT 1	HDCP 1.4	HDCP 1.4	HDCP 1.4
HDMI OUT 3	OUTPUT MODE	: HDMI MODE	HDMI MODE	HDMI MODE	HDMI MODE
HDMI OUT 4	COLOR SPACE	: YCbCr 4:4:4	YCbCr 4:2:0	YCbCr 4:2:0	YCbCr 4:2:0
HDMI OUT 5	COLOR RANGE	: LIMITED RANGE	LIMITED RANGE	LIMITED RANGE	FULL RANGE
	DEEP COLOR	: 24 BIT COLOR	24 BIT COLOR	24 BIT COLOR	24 BIT COLOR
	SCRAMBLE	: SCRAMBLE OFF	SCRAMBLE OFF	SCRAMBLE OFF	SCRAMBLE ON
[SINK DEVICE EDID]					
HDMI OUT 1	MONITOR NAME	: HDMI OUT 1	HD BT OUT 2	HDMI OUT 3	HDMI OUT 4
HDMI OUT 2	LCO-MF24X	: LG Ultra HD	LG Ultra HD	EX-LD40271D	EX-LD40271D
HDMI OUT 3	RESOLUTION	: 1920x1080 148.50MHz	3840x2160 594.00MHz	3840x2160 594.00MHz	3840x2160 533.25MHz
HDMI OUT 4	HDMI / DVI	: HDMI MODE	HDMI MODE	HDMI MODE	HDMI MODE
HDMI OUT 5	COLOR SPACE	: RGB / YCbCr 4:2:2 / YCbCr 4:4:4	RGB / YCbCr 4:2:2 / YCbCr 4:4:4 / YCbCr 4:2:0	RGB / YCbCr 4:2:2 / YCbCr 4:4:4 / YCbCr 4:2:0	RGB / YCbCr 4:2:2 / YCbCr 4:4:4
	DEEP COLOR	: 24 BIT COLOR	24 / 30 / 36 BIT COLOR	24 / 30 / 36 BIT COLOR	24 / 30 BIT COLOR
	PCM FREQUENCY	: 32 / 44.1 / 48 kHz	32 / 44.1 / 48 kHz	32 / 44.1 / 48 kHz	32 / 44.1 / 48 / 88.2 / 96 / 176.4 / 192 kHz
	PCM BIT LENGTH	: 16 / 20 / 24 BIT	16 / 20 / 24 BIT	16 / 20 / 24 BIT	16 / 20 / 24 BIT
	PCM CHANNEL	: 2 CHANNEL	2 CHANNEL	2 CHANNEL	2 CHANNEL
	COMPRESSED AUDIO	: NOT SUPPORTED	NOT SUPPORTED	NOT SUPPORTED	NOT SUPPORTED
	HDR	: NOT SUPPORTED	NOT SUPPORTED	NOT SUPPORTED	NOT SUPPORTED
	SDC	: NOT SUPPORTED	SUPPORTED	SUPPORTED	SUPPORTED
	3D	: NOT SUPPORTED	NOT SUPPORTED	NOT SUPPORTED	NOT SUPPORTED
[SYSTEM STATUS]	TEMPERATURE STATUS	: 53.2 C	STATUS: OK		
	POWER STATUS	: 12.104 V	STATUS: OK		
[VERSION]	HDC-RH421UHD	: 0.06R0 19/10/30			

[Fig. 7.5] VIEW STATUS

JavaScript is used for the HDC WEB browser. When you set the HDC from WEB browser menu, enable JavaScript before setting up. Refer to each browser's help menu if you do not know how to enable JavaScript.

Tip:

IDK tests the HDC under the following environment:

OS : Windows 7 Professional, Windows 10 Professional

WEB browser : Microsoft Internet Explorer 11, Google Chrome 77, Mozilla Firefox 69

7.3.1 WEB browser

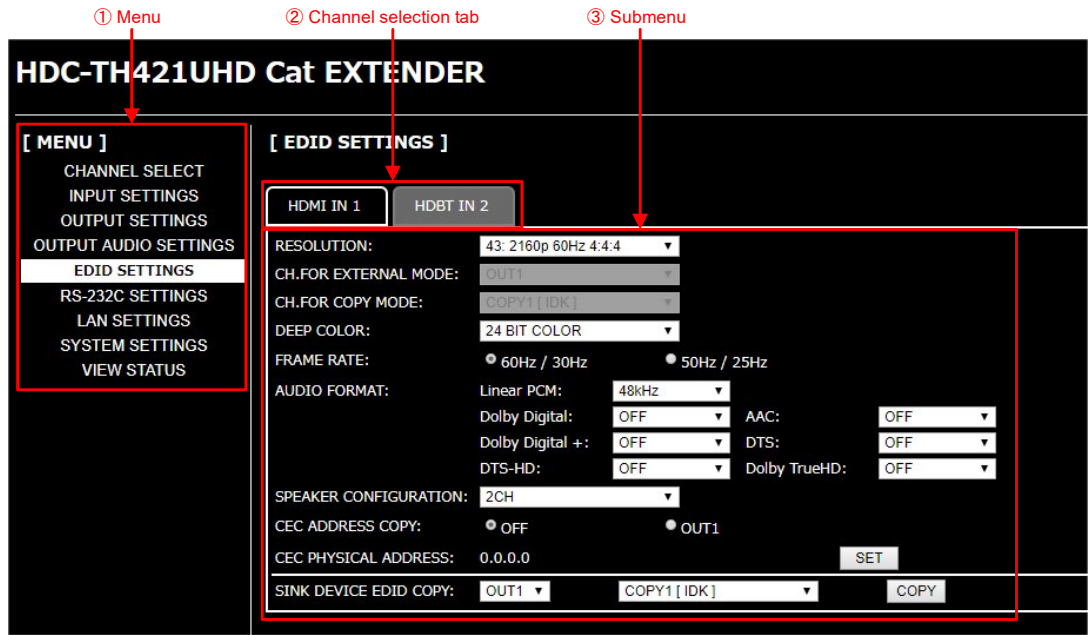

[Fig. 7.6] WEB menu

- ① Select the desired item from the menu to display setting items in the submenu.
- ② If there is a setting item that can be set for each channel, channel tab will be displayed.
- ③ Set items in the submenu by referring to the table below.

[Table 7.1] Form control

Form control	Example	Description
Set/execution button	<input type="button" value="SET"/>	Click the button to execute the desired operation.
Pull down list	<input type="text" value="OUT1"/> ▼	Use the down button to select the desired value.
Arrow button	<input type="text" value="10"/> ▼ ▲	Use the up/down buttons to set the desired value. You also can enter the value directly.
Check box	<input checked="" type="checkbox"/> MENU	Enables and disables by clicking or unclicking the box.
Radio button	<input type="radio"/> OFF <input checked="" type="radio"/> ON	Select [OFF] or [ON].

7.4 Front panel security lockout

Press and hold the “MENU/ENTER” button for three seconds or longer to set/cancel button lock.

If powering off the HDC with the buttons locked, the HDC starts up with the buttons locked next time.

【See: 9.6.1 Grouping front panel security lockout】

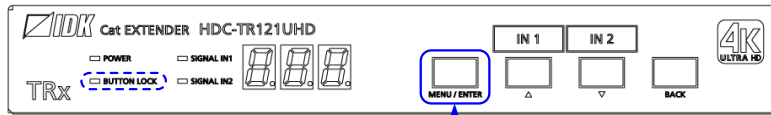

Press and hold MENU/ENTER button to enable/disable button security lockout.



[Fig. 7.7] Locking/unlocking (HDC-TR121UHD)

7.5 Initialization

All user configurable settings can be reset to their respective factory default values by powering the HDC on while pressing and holding the “BACK” button.

Note that after returning to factory default, the previous setting values cannot be restored.

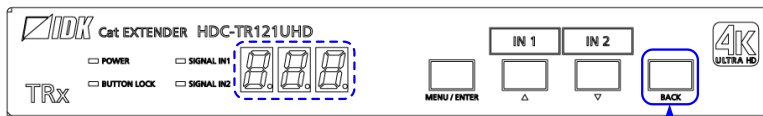

Power on HDC while depressing “BACK” button.



[Fig. 7.8] Initialization

8 Advanced Features

This chapter covers useful features included in the HDC.

8.1 Downconversion

The HDC can downconvert 4K input video into 2K format and output through OUT1.

By default, the downconversion is set to “FOLLOW SINK EDID” that downconverts 4K signal into 2K automatically if the connected sink device support only up to 2K format.

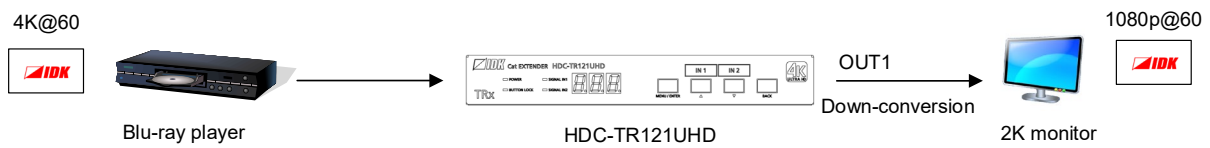

[Fig. 8.1] Downconversion

【See: 9.8.4 Downconversion output】

Note:

Downconverted signal is output from OUT1 only.

8.2 Input channel automatic switching

When signal input status changes by such as removing or inserting cables, the HDC can switch the input channel automatically. The switching priority can be set for each input.

【See: 9.3.1 Automatic input channel switch】

Example 1:

Video is input to IN1 and IN1 is being assigned.

➔ If video is input to IN2, the output video is switched to IN2 automatically.

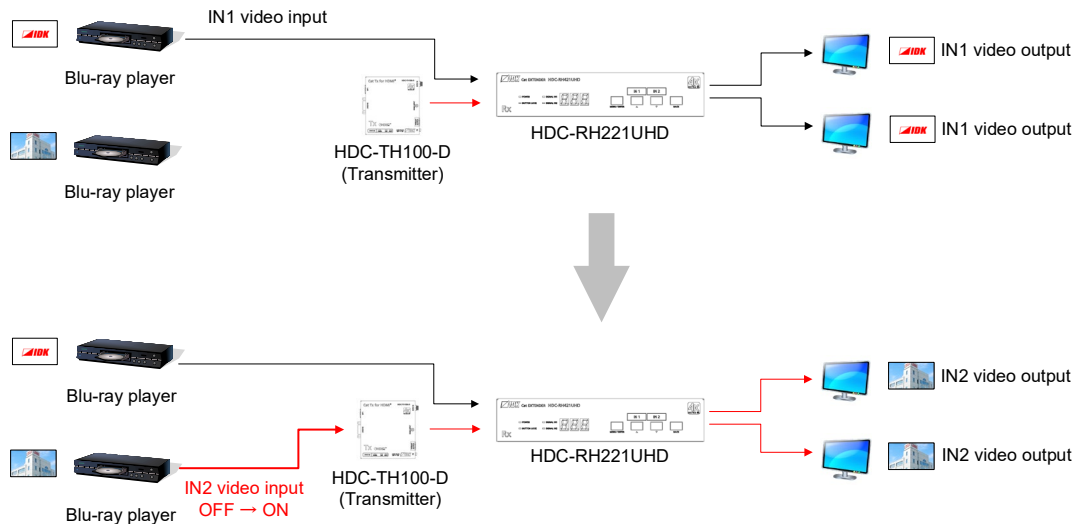

[Fig. 8.2] Automatic input channel switching (Video signal OFF → ON)

Example 2:

Video signals are input to both IN1 and IN2, and IN2 is being assigned.

➔ If video input to IN2 is disconnected, the output video is switched to IN1 automatically.

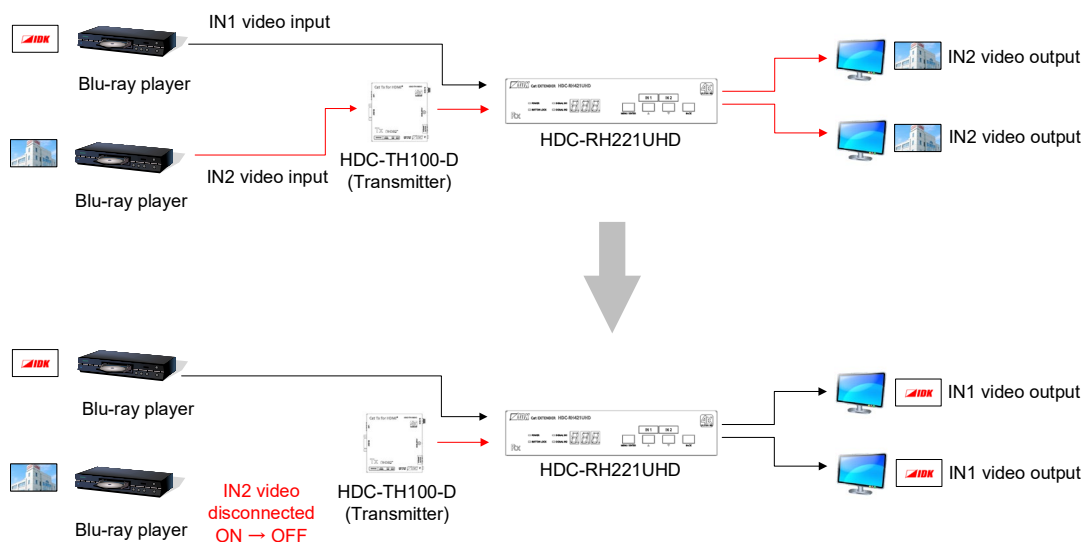

[Fig. 8.3] Automatic input channel switching (Video signal ON → OFF)

Note:

This feature is set to be disabled by default. To enable it, change the setting of “9.3.1 Automatic input channel switch”.

8.3 LAN

The HDC can be accessed and controlled through LAN communication.

The HDC includes the same functionality as switching hub.

If multiple HDC-UHD products are connected through HDBaseT in a system, you can control and check the status of all connected HDC products remotely by connecting a PC to the LAN connector of one HDC-UHD product.

Note:

This feature is set to be disabled by default to avoid loop problems. To enable it, change the setting of “9.10.5 Setting HDBaseT LAN”.

【See: 9.10.5 Setting HDBaseT LAN】

8.3.1 LAN loop problem through HDBaseT

The HDC includes the same functionality as switching hub. The network may be down due to loop problem caused by LAN communication of the HDC. Ensure that the LAN connection is not looped.

【See: 9.10.5 Setting HDBaseT LAN】

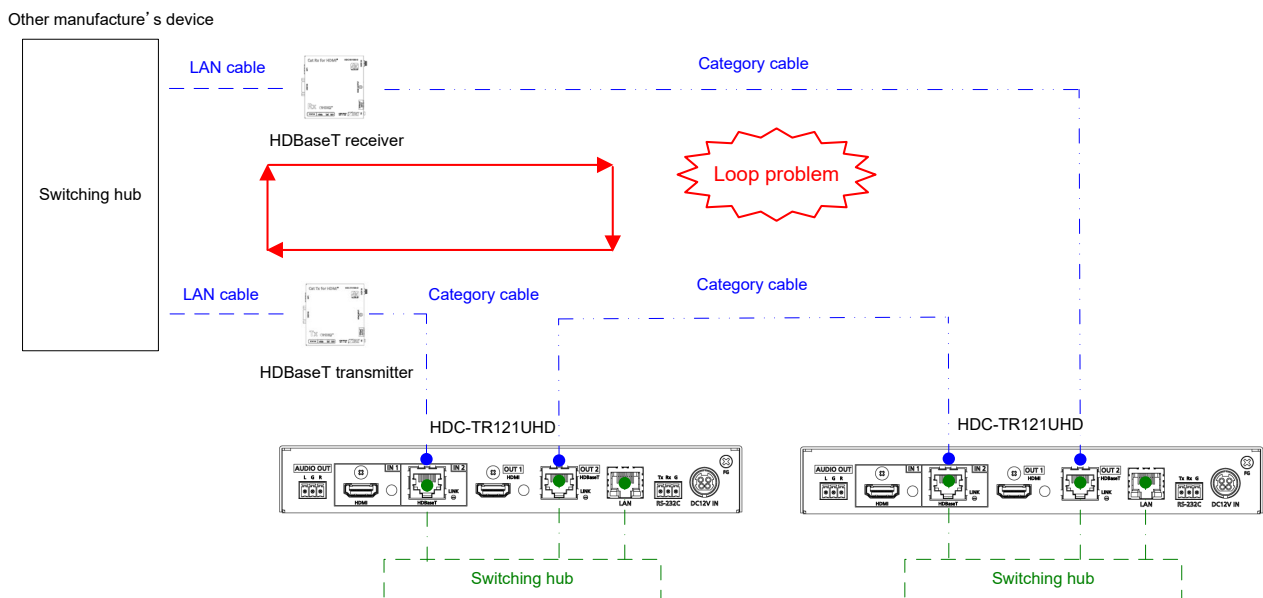

[Fig. 8.4] Loop problem with other manufacture’s device

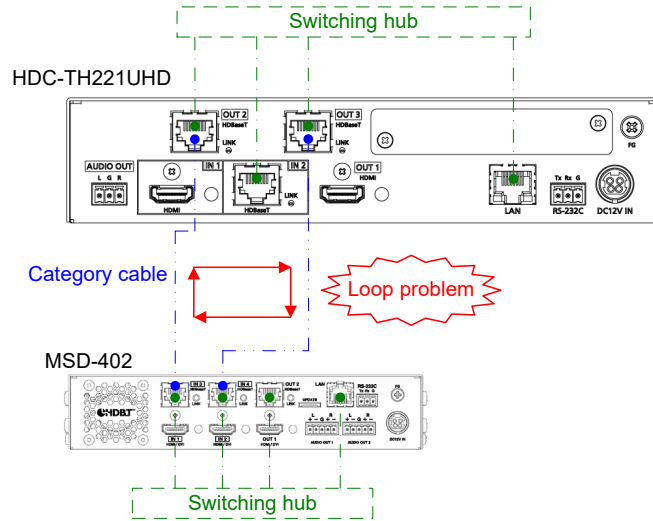

[Fig. 8.5] Loop problem with IDK's device

8.4 RS-232C transmission

Data can be transmitted bidirectionally between the RS-232C connector and HDBaseT input/output connectors.

The following four connectors can send or receive signals:

- ① HDBaseT input connector (IN2)
- ② HDBaseT output connector (OUT2 only)
- ③ HDBaseT output connector (All outputs) only for sending data
- ④ RS-232C connector

If RS-232C transmission is set to be enabled, ensure that data is not duplicated in order to specify that each data is received from which connector. In such case, echo back may not be sent.

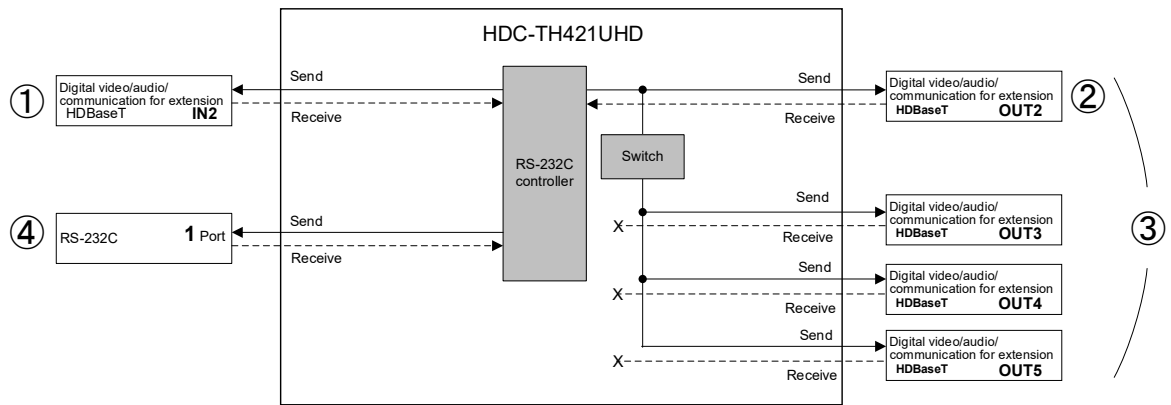

[Fig. 8.6] RS-232C transmission

【See: 9.9.3 RS-232C sending channel】

【See: 9.9.4 RS-232C receiving channel】

The HDC can be controlled using communication commands through RS-232C. Make sure to use the RS-232C connector and set the RS-232C operation mode to “COMMAND MODE”.

In “COMMAND MODE”, the RS-232C communication between HDBaseT IN2 and HDBaseT OUT2/3/4/5 is still available.

【See: 9.9.2 RS-232C operation mode】

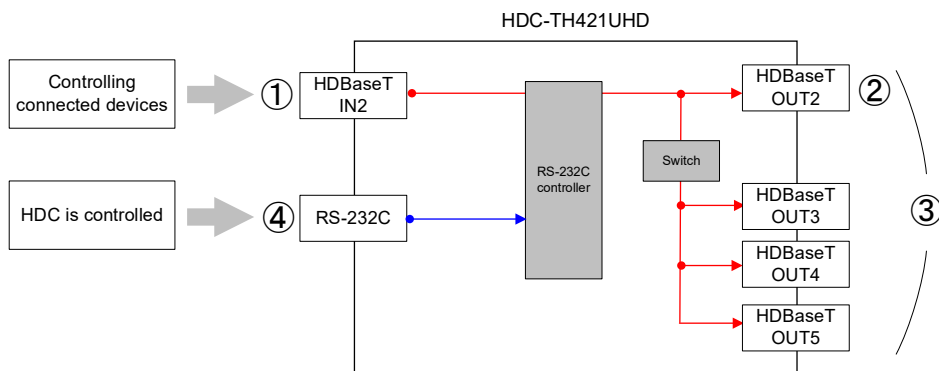

[Fig. 8.7] Setting mode

Example 1:

Sending control signals that is input from IN2 (HDBaseT) to specified connector(s)

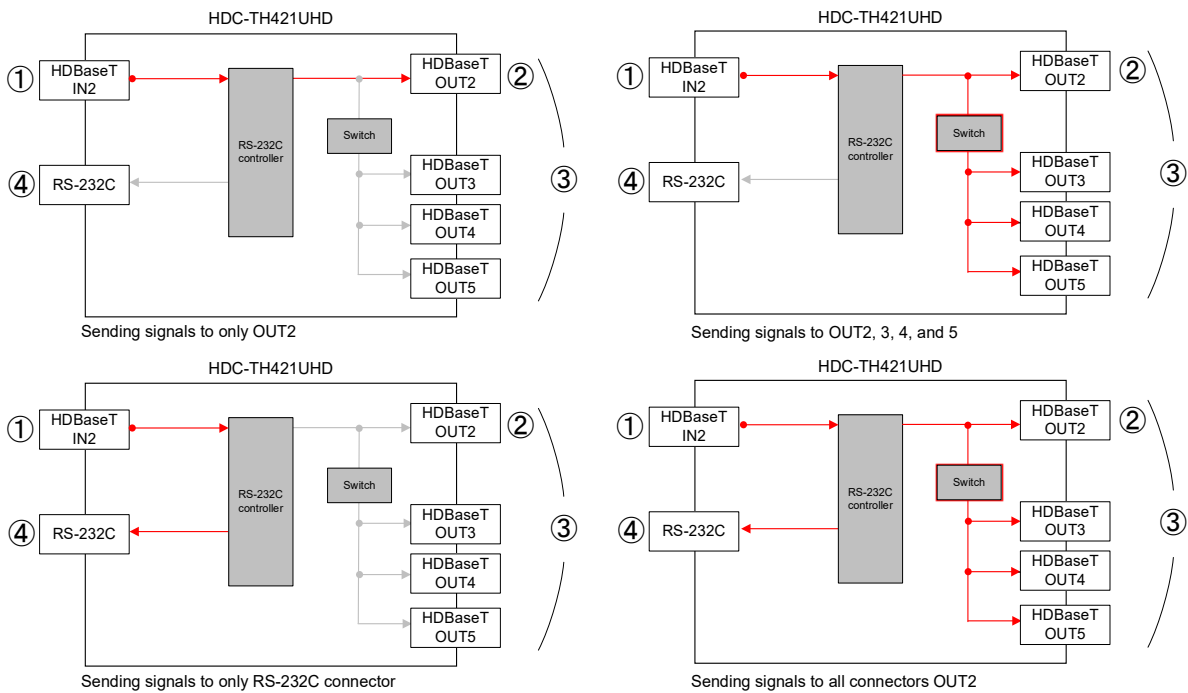

[Fig. 8.8] From IN2 (HDBaseT) connector

Example 2:

Sending control signals that is input from RS-232C to specified connector(s)

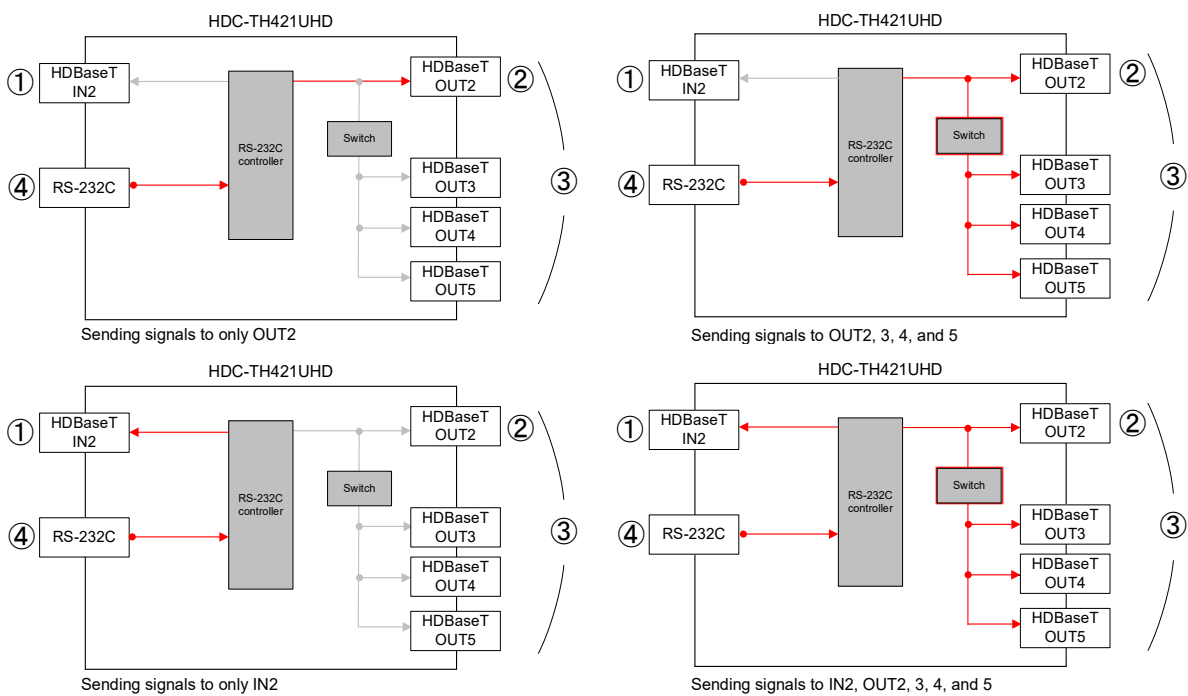

[Fig. 8.9] From RS-232C connector

Notes:

- With RS-232C communication, a few bytes of unnecessary data may be output while the HDC is being powered off or connection is being established. Consider this possible problem when designing control program.
- Immediately after start-up, the communication command control function is disabled until the connection of the sink device is confirmed. Adding "Wait" or retry processing is recommended.

9 Menu

You can set the HDC from the front buttons or Web browser.

[Table 9.1] Menu number and menu name

Front menu	WEB menu	Function	Page
F01 to F03	EDID SETTINGS → SINK DEVICE EDID COPY	Copying EDID	52
F10 to F11	EDID SETTINGS → RESOLUTION	Resolution	53
F12 to F13	EDID SETTINGS → CH.FOR EXTERNAL MODE	External EDID	56
F14 to F15	EDID SETTINGS → CH.FOR COPY MODE	Selecting copied EDID	57
F20 to F21	EDID SETTINGS → DEEP COLOR	Deep Color	58
F40 to F41	EDID SETTINGS → FRAME RATE	Input video frequency	63
F22 to F35	EDID SETTINGS → AUDIO FORMAT	LPCM audio Dolby Digital audio AAC audio Dolby Digital Plus audio DTS audio DTS-HD audio Dolby TrueHD audio	58 to 61
F36 to F37	EDID SETTINGS → SPEAKER CONFIGURATION	Speaker configuration	62
F38 to F39	EDID SETTINGS → CEC ADDRESS COPY	Copying EDID's CEC physical address	63
F50	CHANNEL SELECT → AUTO SWITCHING	Automatic input channel switch	49
F70 to F7n	OUTPUT AUDIO SETTINGS → OUTPUT SIGNAL	Outputting audio	64
F80	CHANNEL SELECT → BUTTON LOCK	Grouping front panel security lockout	65
F90	SYSTEM SETTINGS → VERSION	Version	66
F99	なし	Displaying/Hiding menu	67
C01 to C02	INPUT SETTINGS → HDCP INPUT MODE	HDCP input enabled/disabled	68
C03 to C04	INPUT SETTINGS → NO INPUT MONITORING	No-signal input monitoring	69
C05	INPUT SETTINGS → HDBT LONG REACH MODE	HDBaseT input long reach mode	70
C10 to C1n	OUTPUT SETTINGS → HOTPLUG MASK	Hot plug ignoring duration	71
C20 to C2n	OUTPUT SETTINGS → EDID ERR OUTPUT MODE	Sink device EDID check	72
C30 to C3n	OUTPUT SETTINGS → SIGNAL FORMAT	Output format	73
C40	OUTPUT SETTINGS → DOWN CONVERSION	Downconversion output	74
C45 to C4n	OUTPUT SETTINGS → HDBT LONG REACH MODE	HDBaseT output long reach mode	74
C60	CHANNEL SELECT → IGNORING DURATION	Ignoring duration after automatic switching	50
C70 to C73	RS-232C SETTINGS → PARAMETERS	RS-232C communication	75
C74	RS-232C SETTINGS → CONNECTION MODE	RS-232C operation mode	76
C75 to C78	RS-232C SETTINGS → TRANSMIT ENABLE	RS-232C sending channel	77
C79 to C7B	RS-232C SETTINGS → RECEIVED ENABLE	RS-232C receiving channel	78
C80 to C83	LAN SETTINGS → IP ADDRESS	IP address	79 to 82
C84	LAN SETTINGS → SUBNET MASK	Subnet mask	79 to 82
C85	LAN SETTINGS → PORT NUMBER	TCP port number	79 to 82
C86	LAN SETTINGS → MAC ADDRESS	MAC address	79 to 82
C87 to C89	LAN SETTINGS → HDBT CONNECTION	Setting HDBaseT LAN	82
C90	SYSTEM SETTINGS → ALARM	Alarm	66
L01 to L30	VIEW STATUS → INPUT STATUS	Viewing input information	83
L40 to LLn	VIEW STATUS → SINK DEVICE STATUS	Viewing output information	87
H00 to H02	SYSTEM STATUS	Viewing system status	91

n=1 for HDC-TR121UHD

n=2 for HDC-TH221UHD/HDC-RH221UHD

n=4 for HDC-TH421UHD/HDC-RH421UHD

9.1 Front menu

You can set the following three settings using front buttons:

- Setting video or audio signals (Setting menu)
- Checking operations (Maintenance menu)
- Displaying HDC's status (Status indication menu)

Menu number and target channels vary depending on your model (HDC-TR121UHD, HDC-TH221UHD/HDC-RH221UHD, and HDC-TH421UHD/HDC-RH421UHD). The maximum number of output is 5, and the lists below are based on the number, 5.

■ Setting menus

Set video and audio signals for normal use

[Table 9.2] Setting menu

Menu number	Function	Target channel	Page
F01 to F03	Copying EDID	—	52
F10 to F11	Resolution	IN1/IN2	53
F12 to F13	External EDID	IN1/IN2	56
F14 to F15	Selecting copied EDID	IN1/IN2	57
F20 to F21	Deep Color	IN1/IN2	58
F22 to F23	LPCM audio	IN1/IN2	58
F24 to F25	Dolby Digital audio	IN1/IN2	59
F26 to F27	AAC audio	IN1/IN2	59
F28 to F29	Dolby Digital Plus audio	IN1/IN2	60
F30 to F31	DTS audio	IN1/IN2	60
F32 to F33	DTS-HD audio	IN1/IN2	61
F34 to F35	Dolby TrueHD audio	IN1/IN2	61
F36 to F37	Speaker configuration	IN1/IN2	62
F38	Copying EDID's CEC physical address	IN1	63
F40 to F41	Input video frequency	—	63
F50	Automatic input channel switch	—	49
F70 to F74	Outputting audio	OUT1 to OUT5	64
F80	Grouping front panel security lockout	—	65
F90	Version	—	66
F99	Displaying/Hiding menu	—	67

■ Maintenance menus

Set necessary items for checking operation.

The maintenance menus are not displayed by default. To display the menus, change the setting of “9.6.4 Displaying/Hiding menu”.

[Table 9.3] Maintenance menu

Menu number	Function	Target channel	Page
C01 to C02	HDCP input enabled/disabled	IN1/IN2	68
C03 to C04	No-signal input monitoring	IN1/IN2	69
C05	HDBaseT input long reach mode	IN2	70
C10 to C14	Hot plug ignoring duration	OUT1 to OUT5	71
C20 to C24	Sink device EDID check	OUT1 to OUT5	72
C30 to C34	Output format	OUT1 to OUT5	73
C40	Downconversion output	—	74
C45 to C48	HDBaseT output long reach mode	OUT2 to OUT5	74
C60	Ignoring duration after automatic switching	—	50
C70 to C73	RS-232C communication	—	75
C74	RS-232C operation mode	—	76
C75 to C78	RS-232C sending channel	—	77
C79 to C7B	RS-232C receiving channel	—	78
C80 to C83	IP address	—	79
C84	Subnet mask	—	80
C85	TCP port number	—	81
C86	MAC address	—	82
C87 to C88	Setting HDBaseT LAN	—	82
C90	Alarm	—	66

■ Status indication menus

Display input status, connection status of sink devices, and the HDC's status.

The Status indication menus are not displayed by default. To display the menus, change the setting of “9.6.4 Displaying/Hiding menu”.

[Table 9.4] Status indication menu

Menu number	Function	Page
L01 to L30	Viewing input information	83
L40 to LL4	Viewing output information	87
H00 to H02	Viewing system status	91

9.2 WEB browser menu

The HDC can be controlled from a WEB browser through LAN.

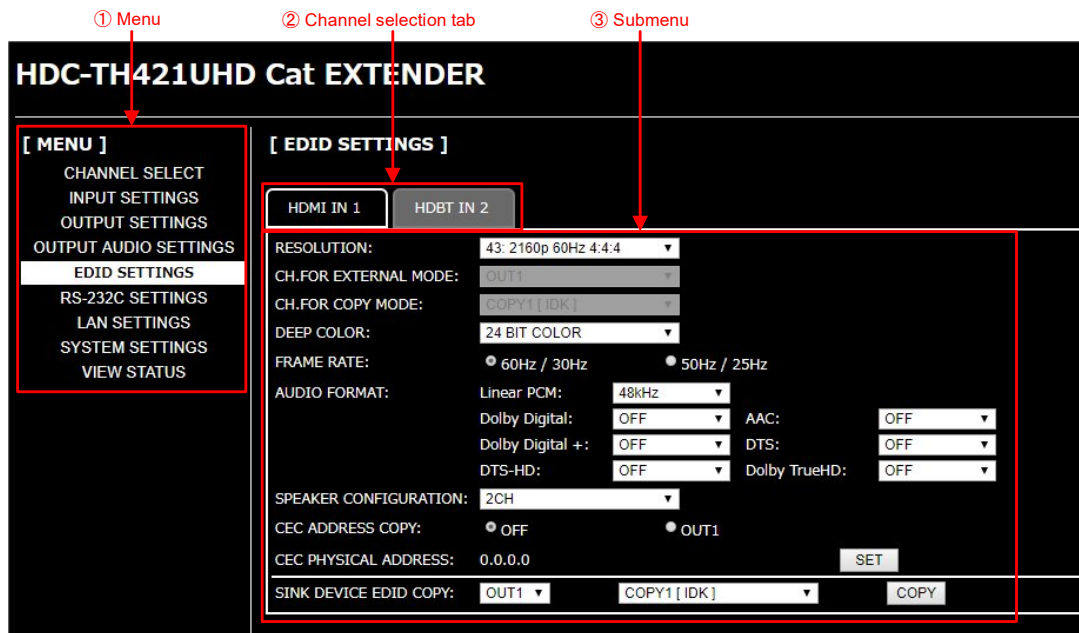

[Fig. 9.1] WEB menu

[Table 9.5] Menu and submenu

Menu	Submenu	Function	Page
CHANNEL SELECT	CHANNEL SELECT	Selecting input channels	32
	BUTTON LOCK	Front panel security lockout	37
		Grouping front panel security lockout	65
	SIGNAL STATUS	Front/side panels	20
	HDBT LONG REACH MODE	HDBaseT input long reach mode	70
		HDBaseT output long reach mode	74
	SIGNAL PRIORITY	Automatic input channel switch	49
	IGNORING DURATION	Ignoring duration after automatic switching	50
INPUT SETTINGS	NAME EDIT	Editing channel name	92
	CHANNEL WINDOW	Selecting input channels	32
	NO INPUT MONITORING	No-signal input monitoring	69
	HDCP INPUT MODE	HDCP input enabled/disabled	68
	HDBT LONG REACH MODE	HDBaseT input long reach mode	70

[Table 9.6] Menu and submenu (Cont'd)

Menu	Submenu	Function	Page
OUTPUT SETTINGS	SIGNAL FORMAT	Output format	73
	EDID ERR.OUTPUT MODE	Sink device EDID check	72
	HOTPLUG MASK	Hot plug ignoring duration	71
	HDBT LONG REACH MODE	HDBaseT output long reach mode	74
	DOWN CONVERSION	Downconversion output	74
EDID SETTINGS	RESOLUTION	Resolution	53
	CH.FOR EXTERNAL MODE	External EDID	56
	CH. FOR COPY MODE	Selecting copied EDID	57
	DEEP COLOR	Deep Color	58
	AUDIO FORMAT	LPCM audio	58
		Dolby Digital audio	59
		AAC audio	59
		Dolby Digital Plus audio	60
		DTS audio	60
		DTS-HD audio	61
	Dolby TrueHD audio	61	
SEPAKER CONFIGURATION	Speaker configuration	62	
CEC ADDRESS COPY	Copying EDID's CEC physical address	63	
SINK DEVICE EDID COPY	Selecting copied EDID	52	
OUTPUT AUDIO SETTINGS	OUTPUT SIGNAL	Outputting audio	64
RS-232C SETTINGS	PARAMETERS	RS-232C communication	75
	CONNECTION MODE	RS-232C operation mode	76
	TRANSMIT ENABLE	RS-232C sending channel	77
	RECEIVED ENABLE	RS-232C receiving channel	78
LAN SETTINGS	LAN SETTING	IP address	79
		Subnet mask	80
		TCP port number	81
		MAC address	82
	HDBT CONNECTION	Setting HDBaseT LAN	82
SYSTEM SETTINGS	ALARM	Alarm	66
	AUTO RELOAD TIME	Automatic updating time	92
	BACKUP/RESTORE	Saving/Restoring all settings	92
	INITIALIZE	Initialization	92
	VERSION	Version	66
VIEW STUTAS	INPUT STATUS	Viewing input information	83
	SINK DEVICE STATUS	Viewing output information	87
	SINK DEVICE EDID	Viewing output information	87
SYSTEM STATUS	TEMPERATURE	Viewing system status	91
	POWER STATUS	Viewing system status	91

9.3 Setting input switching

9.3.1 Automatic input channel switching

The HDC detects video signals of each input and switches input automatically.

Menu F50

WEB menu CHANNEL SELECT → AUTO SWITCHING → SIGNAL PRIORITY

Setting value

[Table 9.7] Setting for automatic input channel switching

Setting	Front	WEB browser
Disabling [Default]	00	OFF
Automatic	01	AUTO
IN1 priority	02	IN 1 priority
IN2 priority	03	IN 2 priority
IN1 fixed	04	IN1 Fixed
IN2 fixed	05	IN2 Fixed

■ Disabling

Disables the automatic switching feature.

■ Automatic

- If new video signal is detected in IN1, IN1 signal will be output automatically.
- If new video signal is detected in IN2, IN2 signal will be output automatically.
- If no signal is detected in the currently selected channel and video is input to the other channel, the other channel's signal will be output automatically.

The last selected input channel has priority. If video signals are input to both IN1 and IN2 at the time of start up, the last selected input has priority.

■ IN1 priority

IN1 has priority. Only if no IN1 signal is detected and IN2 signal is detected, IN2 signal will be output.

■ IN2 priority

IN2 has priority. Only if no IN2 signal is detected and IN1 signal is detected, IN1 signal will be output.

■ IN1 fixed

IN1 signal is output at all times.

■ IN2 fixed

IN2 signal is output at all times.

9.3.2 Ignoring duration after automatic switching

You can set the time from when input channel is switched automatically until the next automatic switching is performed.

The automatic switching is not performed during the set time.

Menu C60

WEB menu CHANNEL SELECT → AUTO SWITCHING → IGNORING DURATION

Setting value

[Table 9.8] Setting masking time

Setting value	Front	WEB browser
0.5 to 10 sec. (by 0.5 sec.) [Default] 1 sec.	0.5 to 10	0.5 to 10
No masking	oFF	oFF

9.4 EDID

You can set EDID to be sent to the source device and can edit parameters as needed.

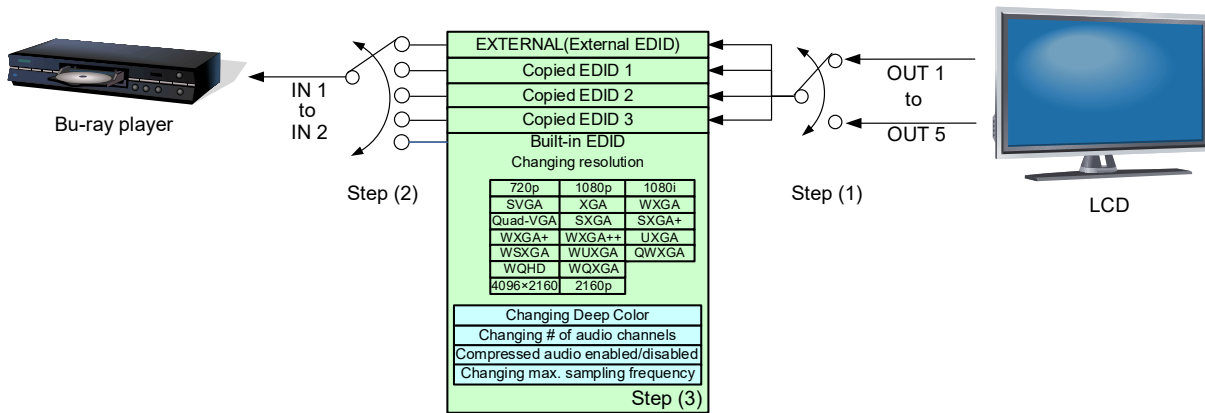

[Fig. 9.2] Setting EDID

Step 1: Select the target sink device for external EDID/copy EDIDs.

Skip this step if the built-in EDID is used.

【See: 9.4.1 Copying EDID】

【See: 9.4.4 Selecting copied EDID】

【See: 9.4.3 External EDID】

Step 2: Set the EDID that will be sent to the source device.

【See: 9.4.2 Resolution】

Step 3: If you use built-in EDID, customize the data as required.

【See: 9.4.5 Deep Color】

【See: 9.4.6 LPCM audio】

【See: 9.4.7 Dolby Digital audio】

【See: 9.4.8 AAC audio】

【See: 9.4.9 Dolby Digital Plus audio】

【See: 9.4.10 DTS audio】

【See: 9.4.11 DTS-HD audio】

【See: 9.4.12 Dolby TrueHD audio】

【See: 9.4.13 Speaker configuration】

9.4.1 Copying EDID

EDID of the sink device is loaded and registered to the HDC. The stored EDID can be treated as built-in EDID by registering the EDID.

Menu	F01 to F03: Copied data 1 to Copied 3
WEB menu	EDID SETTINGS → SINK DEVICE EDID COPY
Setting value	

[Table 9.9] Setting values for copying EDID

Setting	Front buttons	WEB browser
OUT1 [Default]	01	OUT1 COPY1 to 3
OUT2	02	OUT2 COPY1 to 3
OUT3	03	OUT3 COPY1 to 3
OUT4	04	OUT4 COPY1 to 3
OUT5	05	OUT5 COPY1 to 3

To copy EDID:

- Step 1: Save the EDID of sink device to Copied data 1, 2, or 3. Menu number: [F01 to F03]
- Step 2: Select the desired Copied data. Menu number: [F14 to F15] (P.57)
- Step 3: Set EDID Resolution to “COPY (Copied EDID)”. Menu number: [F10 to F11] (P.53)

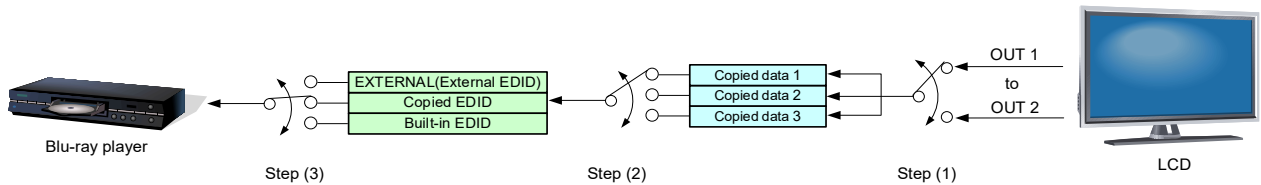

[Fig. 9.3] Copying EDID (Example: HDC-TR121UHD)

Note:

For daisy chain connection, the source device reads EDID of the extender (A) that is directly connected to the source device. If multiple extenders are connected between source device and sink device, follow the procedure below to copy the EDID of sink device.

To read EDID in daisy chain connection:

- Step 1: Copy the EDID of the sink device to the extender (B).
Set EDID to “COPY (Copied EDID)” or “EXTERNAL (External EDID)”
- Step 2: Copy the EDID of the extender (B) to the extender (A).
Set EDID to “COPY (Copied EDID)” or “EXTERNAL (External EDID)”

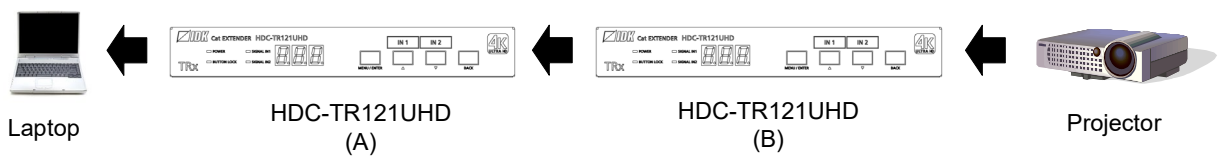

[Fig. 9.4] Reading EDID in daisy chain connection

9.4.2 Resolution

You can set the EDID to be sent to the source device.

In order to use values “03 to 46” which are built-in EDID, set the

“03 to 46 are the built-in EDID. If using the internal EDID, specify the maximum supported resolution.

Menu F10 to F11: IN1 to IN2

WEB menu EDID SETTINGS → RESOLUTION

Setting value [Table 9.10] Maximum resolution of EDID

HDR is supported if external EDID is selected while an HDR-supported sink device is connected for EDID setting or if copied EDID of an HDR-supported sink device is selected for EDID setting.

3D is supported if external EDID is selected while a 3D-supported sink device is connected for EDID setting or if copied EDID of 3D-supported sink device is selected for EDID setting.

【See: 9.4.3 External EDID】

【See: 9.4.4 Selecting copied EDID】

[Table 9.10] Maximum resolution of EDID

Setting value	Maximum resolution	Pixels	Standard	Remarks
01	EXTERNAL (External EDID)	—	—	If no sink device is connected, the last setting will be applied.
02	COPY (Copied EDID)	—	—	If no acquired data, “03” will be applied.
03	1080p (59.94/60)	1920×1080	HDTV	
04	720p	1280×720		
05	1080i	1920×1080		
06	SVGA	800×600	VESA	
07	XGA	1024×768		
08	VESA720p	1280×720		For DVI device input
09	WXGA	1280×768		
10	WXGA	1280×800		
11	Quad-VGA	1280×960		
12	SXGA	1280×1024		
13	WXGA	1360×768		
14	WXGA	1366×768		
15	SXGA+	1400×1050		
16	WXGA+	1440×900		
17	WXGA++	1600×900		(RB)
18	UXGA	1600×1200		
19	WSXGA+	1680×1050		
20	VESA1080p	1920×1080		(RB), for DVI device input

(RB): Reduced Blanking

[Table 9.11] Maximum resolution of EDID Cont'd)

Setting value	Maximum resolution	Pixels	Standard	Remarks
21	WUXGA	1920×1200	VESA	(RB)
22	QWXGA	2048×1152		(RB)
23	WQHD	2560×1440		(RB)
24	WQXGA	2560×1600		(RB)
41	2160p (24/25/30)	3840×2160	UHDTV	
42	2160p (50/59.94/60, 4:2:0)	3840×2160	UHDTV	[Default] (HDBaseT input connector) YCbCr 4:2:0 supported
43	2160p (50/59.94/60, 4:4:4)	3840×2160	UHDTV	[Default] (HDMI input connector) YCbCr 4:2:0, YCbCr 4:2:2, YCbCr 4:4:4 supported
44	4096x2160 (24/25/30)	4096×2160	DCI	
45	4096x2160 (50/59.94/60, 4:2:0)	4096×2160	DCI	YCbCr 4:2:0 supported
46	4096x2160 (50/59.94/60, 4:4:4)	4096×2160	DCI	YCbCr 4:2:0, YCbCr 4:2:2, YCbCr 4:4:4 supported

(RB): Reduced Blanking

Notes:

- For 4096x2160 (“44”, “45”, “46”)
 - The source device may select 3840x2160 (30p, YCbCr 4:4:4) depending on the EDID definition.
 - First set built-in EDID and then select 4096x2160 in the source device side.
- For YCbCr4:2:0 (“42”, “45”)
 - The source device may select 3840x2160 (30p, YCbCr 4:4:4) depending on the EDID definition. First set built-in EDID and then select YCbCr 4:2:0 in the source device side.
- If a source device that does not support 4K is connected to an input connector having 4K EDID, the source device may output DVI signal meaning audio is not output. To output HDMI signal, change the EDID setting to a format other than 4K.

[Table 9.12] Maximum resolution and supported pixels

Max. resolution		Pixels																							
		640x480	800x600	1024x768	1280x720	1280x768	1280x800	1280x960	1280x1024	1360x768*	1366x768*	1400x1050	1440x900	1600x900	1600x1200	1680x1050	1920x1080	1920x1200	2048x1152	2560 x 1440	2560 x 1600	3840x2160 (30p)	4096x2160 (30p)	3840x2160 (60p)	4096x2160 (60p)
01	—	—	—	—	—	—	—	—	—	—	—	—	—	—	—	—	—	—	—	—	—	—	—	—	—
02	—	—	—	—	—	—	—	—	—	—	—	—	—	—	—	—	—	—	—	—	—	—	—	—	—
03	1080p (59.94/60)	Y	Y	Y	N	N	Y	Y	Y	Y	Y	Y	Y	Y	Y	Y	Y	N	N	N	N	N	N	N	N
04	720p	Y	Y	N	Y	N	N	N	N	N	N	N	N	N	N	N	N	N	N	N	N	N	N	N	N
05	1080i	Y	Y	Y	N	N	N	N	N	N	N	N	N	N	N	N	N	N	N	N	N	N	N	N	N
06	800x600	Y	Y	N	N	N	N	N	N	N	N	N	N	N	N	N	N	N	N	N	N	N	N	N	N
07	1024x768	Y	Y	Y	N	N	N	N	N	N	N	N	N	N	N	N	N	N	N	N	N	N	N	N	N
08	1280x720	Y	Y	Y	Y	N	N	N	N	N	N	N	N	N	N	N	N	N	N	N	N	N	N	N	N
09	1280x768	Y	Y	Y	Y	Y	N	N	N	N	N	N	N	N	N	N	N	N	N	N	N	N	N	N	N
10	1280x800	Y	Y	Y	Y	Y	Y	N	N	N	N	N	N	N	N	N	N	N	N	N	N	N	N	N	N
11	1280x960	Y	Y	Y	Y	Y	Y	Y	N	N	N	N	N	N	N	N	N	N	N	N	N	N	N	N	N
12	1280x1024	Y	Y	Y	Y	Y	Y	Y	Y	N	N	N	N	N	N	N	N	N	N	N	N	N	N	N	N
13	1360x768	Y	Y	Y	Y	Y	Y	Y	Y	Y	N	N	N	N	N	N	N	N	N	N	N	N	N	N	N
14	1366x768	Y	Y	Y	Y	Y	Y	Y	Y	Y	N	N	N	N	N	N	N	N	N	N	N	N	N	N	N
15	1400x1050	Y	Y	Y	Y	N	Y	Y	Y	Y	Y	Y	N	N	N	N	N	N	N	N	N	N	N	N	N
16	1440x900	Y	Y	Y	Y	N	Y	Y	Y	Y	Y	Y	Y	N	N	N	N	N	N	N	N	N	N	N	N
17	1600x900	Y	Y	Y	Y	N	Y	Y	Y	Y	Y	Y	Y	Y	N	N	N	N	N	N	N	N	N	N	N
18	1600x1200	Y	Y	Y	Y	N	Y	Y	Y	Y	Y	Y	Y	Y	Y	N	N	N	N	N	N	N	N	N	N
19	1680x1050	Y	Y	Y	Y	N	Y	Y	Y	Y	Y	Y	Y	Y	Y	Y	N	N	N	N	N	N	N	N	N
20	1920x1080	Y	Y	Y	N	N	Y	Y	Y	Y	Y	Y	Y	Y	Y	Y	Y	N	N	N	N	N	N	N	N
21	1920x1200	Y	Y	Y	N	N	Y	Y	Y	N	N	Y	Y	Y	Y	Y	Y	Y	Y	N	N	N	N	N	N
22	2048x1152	Y	Y	Y	N	N	N	Y	Y	N	N	Y	Y	Y	Y	Y	Y	Y	Y	N	N	N	N	N	N
23	2560x1440	Y	Y	Y	N	N	N	N	Y	N	N	Y	Y	Y	Y	Y	Y	Y	Y	Y	N	N	N	N	N
24	2560x1600	Y	Y	Y	N	N	N	N	Y	N	N	Y	Y	Y	Y	Y	Y	Y	Y	Y	Y	N	N	N	N
41	2160p (24/25/30)	Y	Y	Y	N	N	N	N	Y	N	N	Y	Y	Y	Y	Y	Y	Y	Y	Y	Y	Y	Y	N	N
42	2160p (50/59.94/60, 4:2:0)	Y	Y	Y	N	N	N	N	Y	N	N	Y	Y	Y	Y	Y	Y	Y	Y	Y	Y	Y	Y	N	P
43	2160p (50/59.94/60, 4:4:4)	Y	Y	Y	N	N	N	N	Y	N	N	Y	Y	Y	Y	Y	Y	Y	Y	Y	Y	Y	Y	N	Y
44	4096x2160 (24/25/30)	Y	Y	Y	N	N	N	N	Y	N	N	Y	Y	Y	Y	Y	Y	Y	Y	Y	Y	Y	Y	Y	N
45	4096x2160 (50/59.94/60, 4:2:0)	Y	Y	Y	N	N	N	N	Y	N	N	Y	Y	Y	Y	Y	Y	Y	Y	Y	Y	Y	Y	Y	P
46	4096x2160 (50/59.94/60, 4:4:4)	Y	Y	Y	N	N	N	N	Y	N	N	Y	Y	Y	Y	Y	Y	Y	Y	Y	Y	Y	Y	Y	Y

Y: Supported, P: Only YCbCr 4:2:0, N: Not supported, —: Not used

9.4.3 External EDID

You can set the output connector to be recalled when the EDID type is set to “EXTERNAL”.

Menu	F12 to F13: IN1 to IN2
WEB menu	EDID SETTINGS → CH.FOR EXTERNAL MODE
Setting value	

[Table 9.13] Setting values for External EDID

Setting	Front	WEB browser
OUT1 [Default]	01	OUT1
OUT2	02	OUT2
OUT3	03	OUT3
OUT4	04	OUT4
OUT5	05	OUT5

To use external EDID:

Step 1: Select the HDMI output connector to which the target sink device is connected.

Menu number [F12 to F13]

Step 2: Select “EXTERNAL (External EDID)”. Menu number [F10 to F11] (P.53)

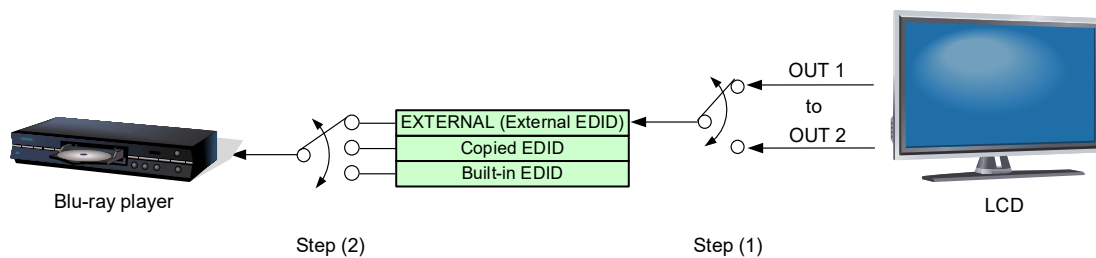

[Fig. 9.5] Registering External EDID (Example: HDC-TR121UHD)

Notes:

- Before setting “Resolution” to “01” (EXTERNAL(External EDID)) in “9.4.2 Resolution”, set this menu first
- Set external EDID again in the following cases:
 - A sink device is replaced while the HDC powered on.
 - A setting of sink device is changed while the HDC powered on.

9.4.4 Selecting copied EDID

You can select a copied EDID.

【See: 9.4.1 Copying EDID】

Menu	F14 to F15: IN1 to IN2
WEB menu	EDID SETTINGS → CH.FOR COPY MODE
Setting value	

[Table 9.14] Selecting copied EDID

Setting	Front	WEB browser
Copied data 1 [Default]	01	COPY1
Copied data 2	02	COPY2
Copied data 3	03	COPY3

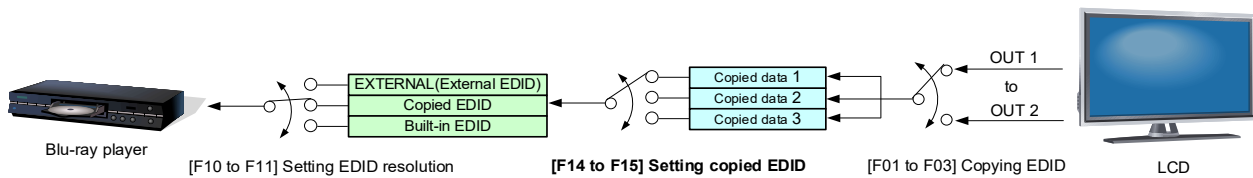

[Fig. 9.6] Setting copied EDID (Example: HDC-TR121UHD)

Note:

Before setting “Resolution” to “01” (EXTERNAL (External EDID)) in “9.4.2 Resolution”, set this menu first.

9.4.5 Deep Color

You can set the color depth to be output from the source device.

Menu	F20 to F21: IN1 to IN2
WEB menu	EDID SETTINGS → DEEP COLOR
Setting value	

[Table 9.15] Deep Color

Setting	Front	WEB browser
24 bit/pixel (8 bit/component) [Default]	24	24-BIT COLOR
30 bit/pixel (10 bit/component)	30	30-BIT COLOR
36 bit/pixel (12 bit/component)	36	36-BIT COLOR

The setting will be applied only if **9.4.2 Resolution** is set to one of "03" to "46".

Note:

If you select "30 bit/pixel (10 bit/component)" or "36 bit/pixel (12 bit/component)", compared to "24 bit/pixel (8 bit/component)", "30 bit/pixel (10 bit/component)" or "36 bit/pixel (12 bit/component)" is transmitted using a higher clock frequency. The clock frequency may cause noise if a poor-quality or an excessively long cable is connected. In such a case, the noise may be removed by setting the color to "24 bit/pixel (8 bit/component)".

For 4K@50/59.94/60 (YCbCr 4:4:4), "24 bit" is selected automatically.

9.4.6 LPCM audio

Menu	F22 to F23: IN1 to IN2
WEB menu	EDID SETTINGS → AUDIO FORMAT → Linear PCM
Setting value	

[Table 9.16] LPCM audio

Setting	Front	WEB browser
32 kHz	32	32 kHz
44.1 kHz	44	44.1 kHz
48 kHz [Default]	48	48 kHz
88.2 kHz	88	88.2 kHz
96 kHz	96	96 kHz
176.4 kHz	176	176.4 kHz
192 kHz	192	192 kHz

The setting will be applied only if **9.4.2 Resolution** is set to one of "03" to "46".

You can set the maximum sampling frequency of LPCM that is output from the source device.

Note:

LC monitors do not support some audio formats. Select an audio format and sampling frequency supported by the device.

9.4.7 Dolby Digital audio

You can set the Dolby Digital audio to be output from the source device.

Menu F24 to F25: IN1 to IN2

WEB menu EDID SETTINGS → AUDIO FORMAT → Dolby Digital

Setting value

[Table 9.17] AC-3 Dolby Digital audio

Setting	Front	WEB browser
OFF [Default]	oFF	OFF
32 kHz	32	32kHz
44.1 kHz	44	44.1kHz
48 kHz	48	48kHz

The setting will be applied only if “9.4.2 Resolution” is set to one of “03” to “46”.

Note:

LC monitors do not support some audio formats. Select an audio format and sampling frequency supported by the device.

9.4.8 AAC audio

You can set the AAC audio to be output from the source device.

Menu F26 to F27: IN1 to IN2

WEB menu EDID SETTINGS → AUDIO FORMAT → AAC

Setting value

[Table 9.18] AAC audio

Setting	Front	WEB browser
OFF [Default]	oFF	OFF
32 khz	32	32kHz
44.1 kHz	44	44.1kHz
48 kHz	48	48kHz
88.2 kHz	88	88.2kHz
96 kHz	96	96kHz

The setting will be applied only if “9.4.2 Resolution” is set to one of “03” to “46”.

Note:

LC monitors do not support some audio formats. Select an audio format and sampling frequency supported by the device.

9.4.9 Dolby Digital Plus audio

You can set the Dolby Digital Plus audio to be output from the source device.

Menu F28 to F29: IN1 to IN2

WEB menu EDID SETTINGS → AUDIO FORMAT → Dolby Digital+

Setting value

[Table 9.19] Dolby Digital Plus audio

Setting	Front	WEB browser
OFF [Default]	oFF	OFF
32 khz	32	32kHz
44.1 kHz	44	44.1kHz
48 kHz	48	48kHz

The setting will be applied only if “9.4.2 Resolution” is set to one of “03” to “46”.

Note:

LC monitors do not support some audio formats. Select an audio format and sampling frequency supported by the device.

9.4.10 DTS audio

You can set the DTS audio to be output from the source device.

Menu F30 to F31: IN1 to IN2

WEB menu EDID SETTINGS → AUDIO FORMAT → DTS

Setting value

[Table 9.20] DTS audio

Setting	Front	WEB browser
OFF [Default]	oFF	OFF
32 khz	32	32kHz
44.1 kHz	44	44.1kHz
48 kHz	48	48kHz
96 kHz	96	96kHz

The setting will be applied only if “9.4.2 Resolution” is set to one of “03” to “46”.

You can set the DTS audio to be output from the source device.

Note:

LC monitors do not support some audio formats. Select an audio format and sampling frequency supported by the device.

9.4.11 DTS-HD audio

You can set the DTS-HD audio to be output from the source device.

Menu F32 to F33: IN1 to IN2

WEB menu EDID SETTINGS → AUDIO FORMAT → DTS-HD

Setting value

[Table 9.21] DTS-HD audio

Setting	Front	WEB browser
OFF [Default]	oFF	OFF
44.1 kHz	44	44.1kHz
48 kHz	48	48kHz
88.2 kHz	88	88.2kHz
96 kHz	96	96kHz
176.4 kHz	176	176.4kHz
192 kHz	192	192kHz

The setting will be applied only if “9.4.2 Resolution” is set to one of “03” to “46”.

Note:

LC monitors do not support some audio formats. Select an audio format and sampling frequency supported by the device.

9.4.12 Dolby TrueHD audio

You can set the Dolby TrueHD audio to be output from the source device.

Menu F34 to F35: IN1 to IN2

WEB menu EDID SETTINGS → AUDIO FORMAT → Dolby TrueHD

Setting value

[Table 9.22] Dolby TrueHD audio

Setting	Front	WEB browser
OFF [Default]	oFF	OFF
44.1 kHz	44	44.1kHz
48 kHz	48	48kHz
88.2 kHz	88	88.2kHz
96 kHz	96	96kHz
176.4 kHz	176	176.4kHz
192 kHz	192	192kHz

The setting will be applied only if “9.4.2 Resolution” is set to one of “03” to “46”.

Note:

LC monitors do not support some audio formats. Select an audio format and sampling frequency supported by the device.

9.4.13 Speaker configuration

You can set the number of multiple channels to be output from the source device.

Menu F36 to F37: IN1 to IN2

WEB menu EDID SETTINGS → SPEAKER CONFIGURATION

Setting value

[Table 9.23] Speaker configuration

Setting	Front	WEB browser
LR [Default]	02	2CH
2.1 channel surround sound	03	2.1CH
5.1 channel surround sound	06	5.1CH
7.1 channel surround sound	08	7.1CH

The setting will be applied only if “9.4.2 Resolution” is set to one of “03” to “46”.

■ **The number of channels and speaker configuration**

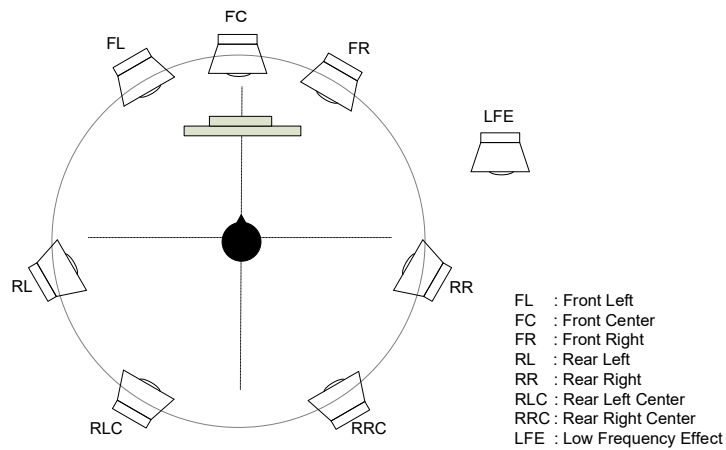

Sound type (Number of speakers)	FL/FR	LFE	FC	RL/RR	RLC/RRC
LR (2)	ON	OFF	OFF	OFF	OFF
2.1 channel surround sound (3)	ON	ON	OFF	OFF	OFF
5.1 channel surround sound (6)	ON	ON	ON	ON	OFF
7.1 channel surround sound (8)	ON	ON	ON	ON	ON

[Fig. 9.7] The number of channels and speaker configuration

Note:

Some LC monitors do not support multi-channel audio.

9.4.14 Copying EDID's CEC physical address

You can copy CEC physical address of the sink device that is connected to OUT1 to the HDC EDID. CEC passes through between IN1 and OUT1.

Menu	F38: IN1
WEB menu	EDID SETTINGS → CEC ADDRESS COPY
Setting value	

[Table 9.24] CEC physical address

Setting	Front	WEB browser
Not copying physical address [Default]	oFF	OFF
Copying physical address	on	OUT1

The setting will be applied only if CEC-supported source device and sink device is connected and "9.4.2 Resolution" is set to one of "03" to "46".

If the CEC physical address of the connected sink device and HDC's address are not the same, the CEC functions, such as input switching in the sink device at start-up, may not work correctly. The problem can be solved by using the CEC physical address that is copied in the HDC.

Note:

CEC system link functions supported by other manufacturers' are not guaranteed to work correctly by this setting. Check the actual configuration.

9.4.15 Input video frequency

For 2160p and 4096x2160 EDID resolutions, the frequency will be 30 Hz or 25 Hz.

Menu	F40 to F41: IN1 to IN2
WEB menu	EDID SETTINGS → FRAME RATE
Setting value	

[Table 9.25] Input video frequency

Setting	Front	WEB browser
OFF [Default]	oFF	60Hz/30Hz
ON	on	50Hz/25Hz

The setting will be applied only if "9.4.2 Resolution" is set to one of "03" to "46".

9.5 Setting audio

9.5.1 Outputting audio

You can enable/disable digital audio that is output from each output channel.

Menu F70 to F74: OUT1 to OUT5

WEB menu OUTPUT AUDIO SETTINGS → OUTPUT SIGNAL

Setting value

[Table 9.26] Outputting audio

Setting	Front	WEB browser
Outputting audio [Default]	on	ON
Not outputting audio	oFF	OFF

9.6 Configuring HDC

9.6.1 Grouping front panel security lockout

You can set front panel security lockout that prevents accidental changes to the controller settings.

Menu F80
 WEB menu CHANNEL SELECT → BUTTON LOCK
 Setting value

[Table 9.27] Target buttons of security lockout

Target button	Front*	WEB browser
All buttons [Default]	ALL	Click [ALL].
MENU/ENTER and BACK buttons	SE	Click [MENU/ENTER] and [BACK].
CHANNEL (▲▼) buttons	CH	Click [CHANNEL].

*To enable/disable the security lockout from the front, press and hold the "MENU/ENTER" button for three seconds.

9.6.2 Alarm

In case an abnormality is detected in power voltage (higher or lower than DC+12 V±10 %) or internal temperature, an alarm is output and “E” appears on the segment display.

Menu **C90**
 WEB menu **SYSTEM SETTINGS → ALARM**
 Setting value

[Table 9.28] Alarm output

Setting	Front	WEB browser
Enabling [Default]	on	ON
Disabling	oFF	OFF

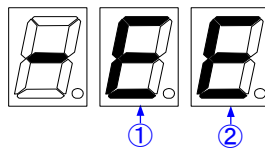

[Fig. 9.8] How alarm is displayed

#	Description
①	Abnormality in internal temperature is detected.
②	Power voltage is higher or lower than DC+12 V±10 %.

Note:

In case an alarm is output, the HDC may have problems. Please contact us.

9.6.3 Version

Menu **F90**
 WEB menu **VIEW STATUS → VERSION**

You can view the firmware version.

9.6.4 Displaying/Hiding menu

You can display/hiding maintenance menu and status indication menu.

Menu F99

Setting value

[Table 9.29] Setting menu display

Setting	Front
Hiding [Default]	oFF
Displaying (Hiding at next start-up)	on
Always displaying (Displaying at next start-up)	ALL

Setting value	Menu		
	Setting menu	Maintenance	Status indication
oFF	Displayed	Hidden	Hidden
on	Displayed	Hidden at next start-up	Hidden at next start-up
ALL	Displayed	Displayed	Displayed

Note:

This menu cannot be set from WEB browser.

9.7 Setting input

9.7.1 HDCP input enabled/disabled

Menu	C01 to C02: IN1 to IN2
WEB menu	INPUT SETTINGS → HDCP INPUT MODE
Setting value	

[Table 9.30] HDCP input

Setting	Front	WEB browser
Enabling HDCP 2.2 [Default]	2.2	HDCP2.2
Enabling HDCP 1.4	1.4	HDCP1.4
Disabling HDCP	oFF	DISABLE

Some source devices negotiate with the connected device to determine if HDCP encryption is supported. After this negotiation, the source device determines whether HDCP signal encryption is enforced or not. This process takes place with some source device, even if the content being presented is not copyright protected. The HDC is HDCP compliant, if it is connected to a display device that does not support HDCP, even unprotected AV content may not be successfully displayed. Under these circumstances and if the content is indeed not protected, the problem can be solved by setting this menu to [DISABLE].

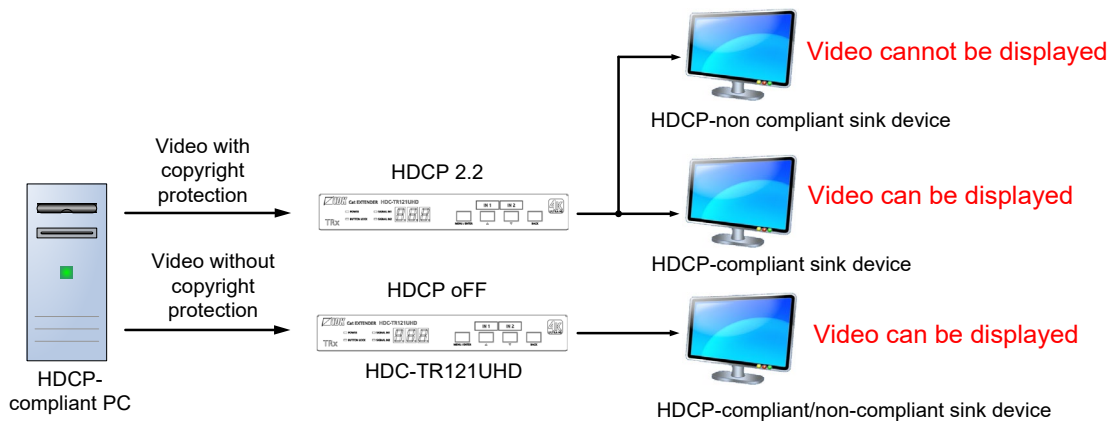

[Fig. 9.9] HDCP-compliant and HDCP non-compliant sink device

Notes:

Set this setting to HDCP 2.2 or HDCP 1.4 in order to display video with copyright protection.

- HDCP 2.2 (stream type 0) contents can be displayed on sink devices supporting HDCP 2.2/HDCP 1.4.
- HDCP 2.2 (stream type 1) contents can be displayed on sink devices supporting HDCP 2.2 but cannot be displayed on sink devices supporting HDCP 1.4.

9.7.2 No-signal input monitoring

If you change the EDID settings of the HDC or power the HDC off/on, the source device may not output a video signal. Use this menu to set the monitoring time. This is the interval beginning when a source device is not outputting a signal; and ending at the point when the HDC requests an output from that source device.

Menu C03 to C04: IN1 to IN2
 WEB menu INPUT SETTINGS → NO INPUT MONITORING
 Setting value

[Table 9.31] No-signal input monitoring

Setting	Front	WEB browser
2 sec. to 15 sec. [Default] 10 sec.	02 to 15	2 to 15
OFF	oFF	OFF

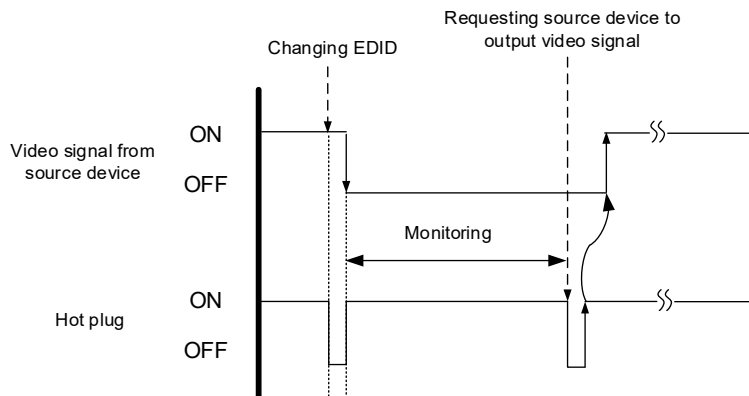

[Fig. 9.10] Monitoring absence of input

Notes:

If you are using the monitor power-saving or dual monitor features on your PC, set this feature to “OFF”. This will avoid potentially unpredictable operation.

When using this feature, ensure that the “monitoring time” is set for a value greater than the amount of time needed for the source to provide an output signal.

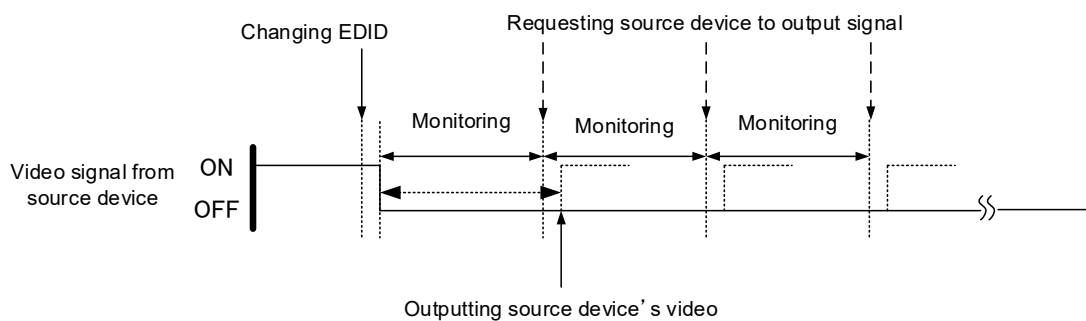

[Fig. 9.11] Repeating output reset

9.7.3 HDBaseT input long reach mode

You can enable/disable long reach mode for HDBaseT input.

Menu C05: IN2

WEB menu INPUT SETTINGS → HDBT LONG REACH MODE

Setting value

[Table 9.32] HDBaseT input long reach mode

Setting		Front	WEB browser
Disabling	(Up to 328 ft. (100 m)) [Default]	oFF	OFF
Enabling	(Up to 492 ft. (150 m))	on	ON

With long reach mode, up to 1080p (24 bit)/dot clock 148 MHz is supported when using with IDK's HDBaseT product. Set the HDC's EDID to 1080p or less or set the connected device's output to a supported signal format.

9.8 Setting output

9.8.1 Hot plug ignoring duration

Time for ignoring the video output request signals sent from the sink device.

- Menu C10 to C14: OUT1 to OUT5
- WEB menu OUTPUT SETTINGS → HOTPLUG MASK
- Setting value

[Table 9.33] Hot plug ignoring duration

Setting	Front	WEB browser
Not ignoring request signals [Default]	oFF	OFF
2 to 15 [sec.]	02 to 15	2 to 15

If the request signals are repeated in a short cycle, the HDC processes video output from the first cycle. As a result, video may not be output. This problem can be solved by setting the ignoring time.

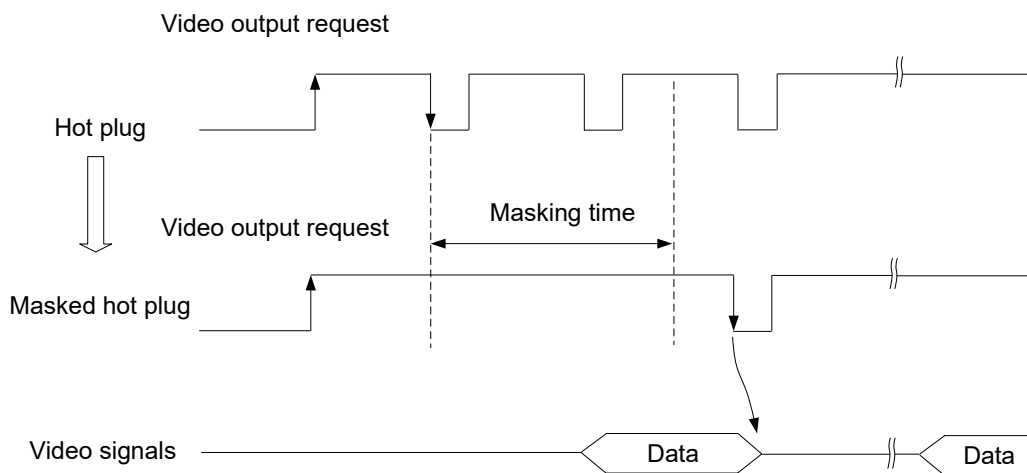
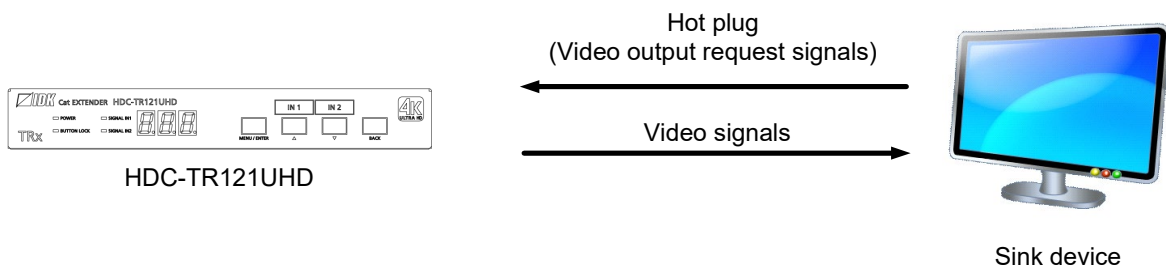

[Fig. 9.12] Hot plug mask

9.8.2 Sink device EDID check

You can set the sink device's EDID checking mode.

Menu	C20 to C24: OUT1 to OUT5
WEB menu	OUTPUT SETTINGS → EDID ERR OUTPUT MODE
Setting value	

[Table 9.34] Sink device EDID check

Setting	Front	WEB browser
In case of EDID load error, the sink device is treated as a DVI device [Default]	oFF	OFF
In case of EDID load error, the sink device is treated as a HDMI device without SCDC	Er1	ERROR1
Always treats sink device as a HDMI device without SCDC	AL1	ALWAYS1
In case of EDID load error, the sink device is treated as a HDMI device with SCDC	Er2	ERROR2
Always treats sink device as a HDMI device with SCDC	AL2	ALWAYS2

The HDC gets EDID from the sink device and determines if the sink device is an HDMI device or DVI device in order to output HDMI signals. However, if the HDC cannot get EDID for some reasons, problems such as no audio output and the like may occur. In these cases, HDC recognized the connected sink device is HDMI or DVI device and output signal as HDMI or DVI mode depending on its setting.

Notes:

- If setting this menu to a value other than the default (oFF, OFF), set “**9.4.2 Resolution**” to a supported resolution other than “01” (External EDID).
- This setting is applied when HDMI signal is input and “**9.8.3 Output format**” is set to a format other than DVI.

【See: 9.8.3 Output format】

9.8.3 Output format

You can set the color space to be sent to the sink device.

Menu	C30 to C34: OUT1 to OUT5
WEB menu	OUTPUT SETTINGS → SIGNAL FORMAT
Setting value	

[Table 9.35] Output format

Setting	Front	WEB browser
AUTO [Default]	FoL	FOLLOW SINK DEVICE
RGB output	rgb	HDMI RGB MODE
YCbCr 4:2:2 output	422	HDMI YCbCr 4:2:2 MODE
YCbCr 4:4:4 output	444	HDMI YCbCr 4:4:4 MODE
DVI output	d	DVI MODE
YCbCr 4:2:0 output	420	HDMI YCbCr 4:2:0MODE

The sink device selects the best color space for the color space of the input video automatically, but if for some reason the sink device cannot select the color space, set the desired color space in HDC.

Notes:

- This setting is applied when HDMI signal is input.
- When 4K YCbCr 4:4:4 signal is input, the HDC outputs the signal at YCbCr 4:2:0 to the sink device supporting YCbCr 4:2:0 (not supporting YCbCr 4:4:4).
- YCbCr 4:2:0 output is available only for 4K@50/59.94/60 output, for other resolution the format is set to "AUTO".
- For HDBaseT output, if 4K YCbCr 4:4:4 signal is input, it is output at YCbCr 4:2:0 automatically.

9.8.4 Downconversion output

The HDC can downconvert 2160p into 1080p. Only OUT1 supports this feature.

Menu	C40: OUT1
WEB menu	OUTPUT SETTINGS → DOWN CONVERSION
Setting value	

[Table 9.36] Downconversion

Setting	Front	WEB browser
Automatic* [Default]	FoL	FOLLOW SINK EDID
Disabling	oFF	OFF
Enabling	on	1080p

*Automatic: If the sink device supports only up to 2K, signals are downconverted automatically.

[Table 9.37] Downconverted resolution

Input resolution	Converted resolution
3840x2160p 24Hz	1920x1080p 24Hz
3840x2160p 25Hz	1920x1080p 25Hz
3840x2160p 30Hz	1920x1080p 30Hz
3840x2160p 50Hz	1920x1080p 50Hz
3840x2160p 60Hz	1920x1080p 60Hz

9.8.5 HDBaseT output long reach mode

You can enable/disable long reach mode for HDBaseT output.

Menu	C45 to C48: OUT2 to OUT5
WEB menu	OUTPUT SETTINGS → HDBT LONG REACH MODE
Setting value	

[Table 9.38] HDBaseT output long reach mode

Setting	Front	WEB browser
Disabling (Up to 328 ft. (100 m)) [Default]	oFF	OFF
Enabling (Up to 492 ft. (150 m))	on	ON

With long reach mode, up to 1080p (24 bit)/dot clock 148 MHz is supported when using with IDK's HDBaseT product.

9.9 Setting RS-232C

9.9.1 RS-232C communication

You can set the RS-232C communication.

Menu C70: Baud rate
 C71: Data bit length
 C72: Parity check
 C73: Stop bit

WEB menu RS-232C SETTINGS → PARAMETERS → BAUD RATE
 RS-232C SETTINGS → PARAMETERS → DATA BIT LENGTH
 RS-232C SETTINGS → PARAMETERS → PARITY
 RS-232C SETTINGS → PARAMETERS → STOP BIT

Setting value

[Table 9.39] RS-232C communication

Item	Setting	Front	WEB browser
Baud rate [bps]	4800 bps	48	4800bps
	9600 bps [Default]	96	9600bps
	14400 bps	144	14400bps
	19200 bps	192	19200bps
	38400 bps	384	38400bps
Data bit length [bit]	8 [Default]	8	8
	7	7	7
Parity check	NONE [Default]	non	NONE
	ODD	odd	ODD
	EVEN	En	EVEN
Stop bit [bit]	1 [Default]	1	1
	2	2	2

Note:

All RS-232C and HDBaseT connectors can be set simultaneously.

9.9.2 RS-232C operation mode

You can set the transmission mode for RS-232C communication.

Menu	C74
WEB menu	RS-232C SETTINGS → HDBT CONNECTION
Setting value	

[Table 9.40] RS-232C operation mode

Setting	Front	WEB browser
Command mode [Default]	00	COMMAND MODE
Transmission mode	01	TRANSMIT MODE

■ Command mode

Controls the HDC using RS-232C communication commands from the RS-232C connector

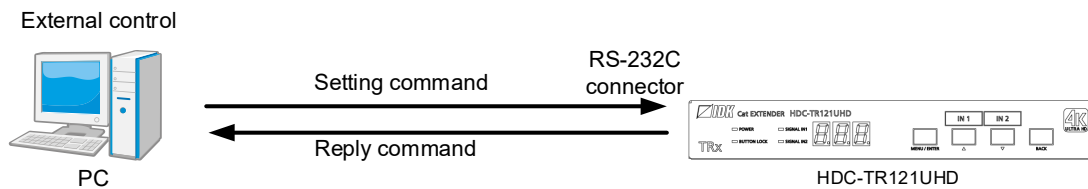

[Fig. 9.13] Command mode (example)

■ Transmission mode

Controls devices that are connected through the HDBaseT connectors

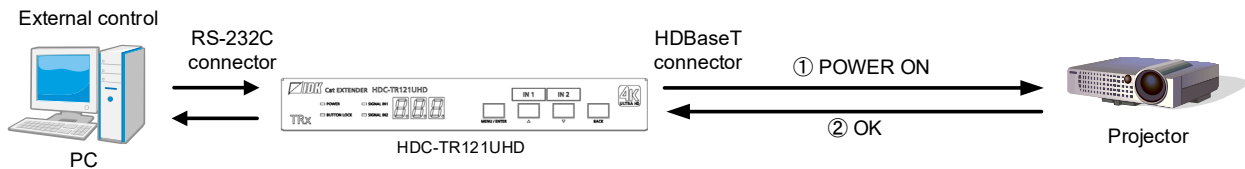

[Fig. 9.14] Transmission mode (example)

9.9.3 RS-232C sending channel

You can set the destination(s) of the sending data in transmission mode.

【See: 9.9.2 RS-232C operation mode】

Menu C75: IN2
 C76: OUT2 only
 C77: All outputs
 C78: RS-232C

WEB menu RS-232C SETTINGS → HDBT CONNECTION → TRANSMIT ENABLE →
 → RS-232C
 → HDBaseT IN2
 → HDBaseT OUT (OUT2, ALL)

Setting value

[Table 9.41] RS-232C sending channel

Setting	Front	WEB browser
Enabling RS-232C sending	on	Check box ON (RS-232C, HDBaseT IN2, HDBaseT OUT(OUT2, ALL))
Disabling RS-232C sending [Default]	oFF	Check box OFF (RS-232C, HDBaseT IN2, HDBaseT OUT(OUT2, ALL))

Select the connector(s) to be set from the following connectors:

- ① HDBaseT input connector (IN2)
- ② HDBaseT output connector (OUT2 only)
- ③ HDBaseT output connector (All outputs)
- ④ RS-232C connector

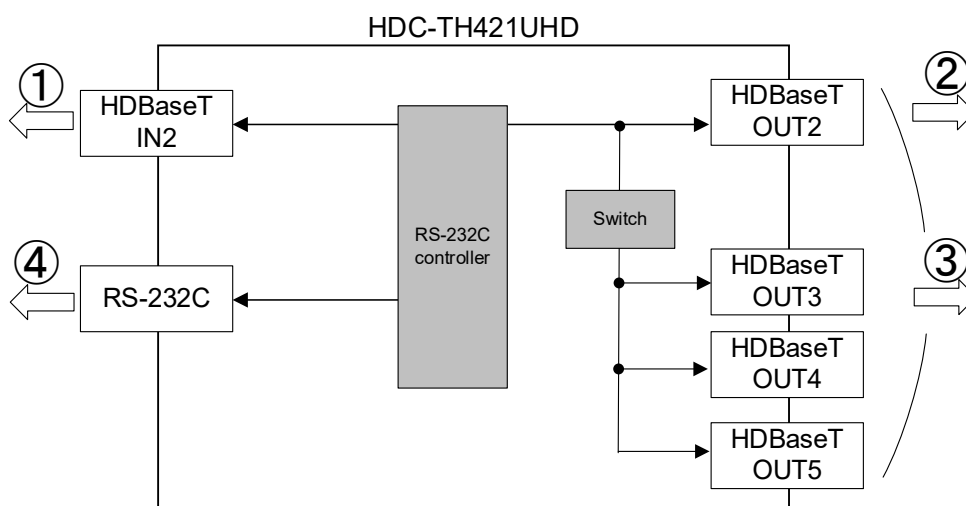

[Fig. 9.15] Receiving channel

Note:

Received data is not sent to the connector that receives the data.

9.9.4 RS-232C receiving channel

You can set the connector (s) that receives data in transmission mode.

【See: 9.9.2 RS-232C operation mode】

Menu C79: IN2

C7A: OUT2

C7b: RS-232C

WEB menu RS-232C SETTINGS → HDBT CONNECTION → RECEIVED ENABLE →

→ RS-232C

→ HDBaseT IN2

→ HDBaseT OUT2

Setting value

[Table 9.42] RS-232C receiving channel

Setting	Front	WEB browser
Enabling RS-232C receiving	on	Check box ON (RS-232C, HDBaseT IN2, HDBaseT OUT2)
Disabling RS-232C receiving [Default]	oFF	Check box OFF (RS-232C, HDBaseT IN2, HDBaseT OUT2)

Select the connector(s) to be set from the following connectors:

- ① HDBaseT input connector (IN2)
- ② HDBaseT output connector (OUT2)
- ③ RS-232C connector

The received data will be sent to the channel that is selected in “9.9.3 RS-232C sending channel”.

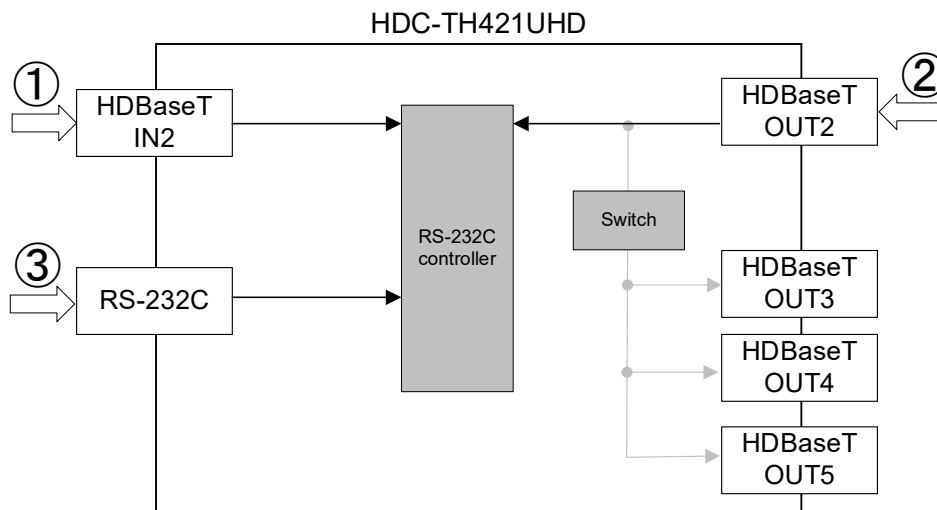

[Fig. 9.16] Sending channel

Notes:

- If setting multiple channels to be received, ensure that data is not duplicated in order to specify that each data is received from which connector.
- RS-232C data cannot be received from HDBaseT OUT3, OUT4, or OUT5.

9.10 Setting LAN

The HDC can be accessed and controlled through LAN communication.

The HDC does not support automatic acquisition of IP address using DHCP (Dynamic Host Configuration Protocol). If you use the HDC in a network with DHCP, use a fixed IP address. If controlling peripheral devices connected over LAN from the HDC, use multiple fixed IP addresses.

9.10.1 IP address

You can set the IP address.

Menu C80: ①
 C81: ②
 C82: ③
 C83: ④

WEB menu LAN SETTINGS → PARAMETERS → IP ADDRESS

Setting value

[Table 9.43] IP address

Setting		Front	WEB browser
000.000.000.000 to 255.255.255.255 : [Default] 192.168.1.199	①	000 to 255	0 to 255
	②	000 to 255	0 to 255
	③	000 to 255	0 to 255
	④	000 to 255	0 to 255

192 . 168 . 001 . 199
 ↑ ↑ ↑ ↑
 ① ② ③ ④

Note:

If the HDC is connected to multiple networks, the same IP address is assigned to multiple networks. In this case, an error may be reported.

9.10.2 Subnet mask

You can set the subnet mask.

Menu C84

WEB menu LAN SETTINGS → PARAMETERS → SUBNET MASK

Setting value

[Table 9.44] Subnet mask

Setting	Front	Setting	Front
0.0.0.0	1	255.255.0.0	17
128.0.0.0	2	255.255.128.0	18
192.0.0.0	3	255.255.192.0	19
224.0.0.0	4	255.255.224.0	20
240.0.0.0	5	255.255.240.0	21
248.0.0.0	6	255.255.248.0	22
252.0.0.0	7	255.255.252.0	23
254.0.0.0	8	255.255.254.0	24
255.0.0.0	9	255.255.255.0 [Default]	25
255.128.0.0	10	255.255.255.128	26
255.192.0.0	11	255.255.255.192	27
255.224.0.0	12	255.255.255.224	28
255.240.0.0	13	255.255.255.240	29
255.248.0.0	14	255.255.255.248	30
255.252.0.0	15	255.255.255.252	31
255.254.0.0	16	255.255.255.254	32

Setting	WEB browser
000.000.000.000 to 255.255.255.254 : [Default] 255.255.255.0	000 to 255
	000 to 255
	000 to 255
	000 to 254

9.10.3 TCP port number

Menu C85
 WEB menu LAN SETTINGS → PARAMETERS → PORT NUMBER
 Setting value

[Table 9.45] TCP port number

Setting	Front	WEB browser
Up to 4 connections can be used [Default]	4	CONNECTION: 4
Up to 8 connections can be used	8	CONNECTION: 8

“Up to 4 connections can be used” : Connections will be divided into 4 for WEB browser control (HTTP port number is fixed 80) and 4 for communication command control at maximum.

“Up to 8 connections can be used” : Connections will be assigned to 8 communication command controls at maximum.

Notes:

- If setting this menu to “Up to 8 connections can be used”, WEB browser cannot be used any more.
- You can change the port number from communication command or WEB browser.
- For communication command control, set the port number to a value from “1100”, “6000” to “6999”.

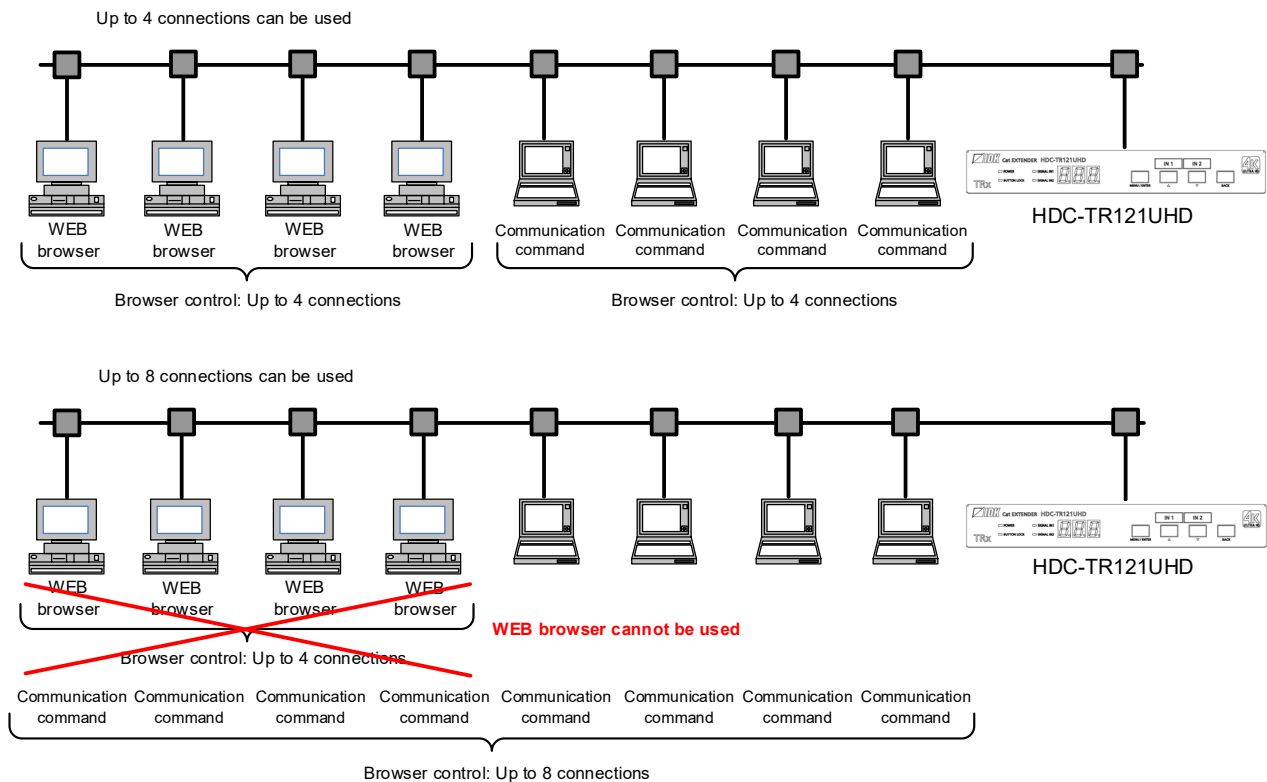

[Fig. 9.17] 8 connection setting

9.10.4 MAC address

Menu C86
 WEB menu LAN SETTINGS → PARAMETERS → MAC ADDRESS

You can display the HDC's MAC address.

9.10.5 Setting HDBaseT LAN

You can enable/disable the LAN capabilities of each HDBaseT I/O connector.

Menu C87 : ① HDBaseT IN2
 C88 : ② HDBaseT OUT2, HDBaseT OUT3
 C89 : ③ HDBaseT OUT4, HDBaseT OUT5
 WEB menu LAN SETTINGS → HDBT COMMUNICATION
 Setting value

[Table 9.46] HDBaseT LAN

Setting	Front	WEB browser
Disabling LAN [Default]*	oFF	Check box OFF (HDBaseT IN2, HDBaseT OUT2,3, HDBaseT OUT4,5)
Enabling LAN	on	Check box ON (HDBaseT IN2, HDBaseT OUT2,3, HDBaseT OUT4,5)

*This feature is set to be disabled by default to avoid loop problems. Enable this menu for LAN communication from HDBaseT connector.

【See: 8.3.1 LAN loop problem through HDBaseT】

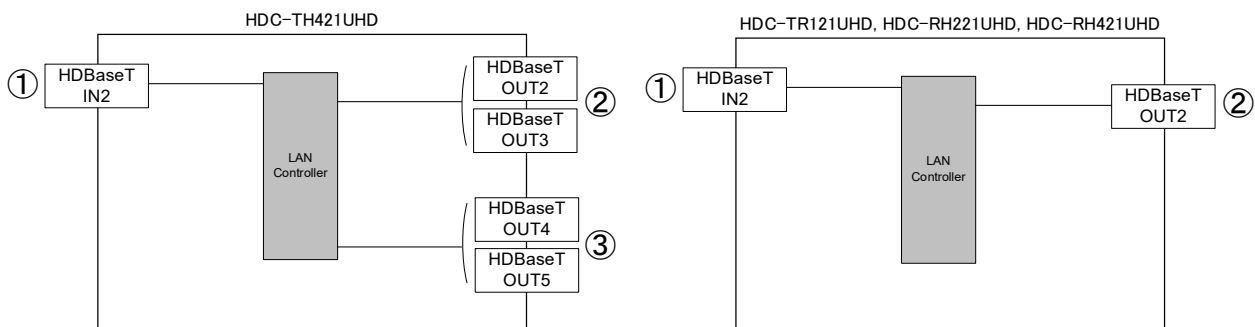

[Fig. 9.18] LAN functionality

Note:

The LAN functionality between HDBaseT OUT2 and HDBaseT OUT3 or between HDBaseT OUT4 and HDBaseT OUT5 cannot be set separately.

9.11 Status indication

9.11.1 Viewing input information

You can view the information for input.

Menu L01 to L30

WEB menu VIEW STATUS → INPUT STAUS

[Table 9.47] Input status

Menu number	Value to be displayed	Description
● HDMI/DVI mode and color depth of input video		
L01(IN1), L02(IN2)	H24	HDMI mode 24 bit/pixel (8bit/component)
	H30	HDMI mode 30 bit/pixel (10bit/component)
	H36	HDMI mode 36 bit/pixel (12bit/component)
	d24	DVI mode 24 bit/pixel (8bit/component)
	- - -	No signal is input.
● Presence of input HDCP		
L03(IN1), L04(IN2)	on	With HDCP
	oFF	Without HDCP
	- - -	No signal is input.
● Presence of input video HDCP encryption (Encryption from source device)		
L05(IN1), L06(IN2)	1.4	Encrypted (HDCP 1.4)
	2.2	Encrypted (HDCP 2.2)
	oFF	Not encrypted
	- - -	No signal is input.
● Color space of input video		
L07(IN1), L08(IN2)	rgb	RGB
	422	YCbCr 4:2:2
	420	YCbCr 4:2:0
	444	YCbCr 4:4:4
	- - -	Unknown, No signal is input.
● Input video frequency		
L09(IN1), L10(IN2)	59.9	Input vertical synchronous frequency (example: 59.94 Hz)
	- - -	No signal is input.
● DDC power input state		
L11(IN1), L12(IN2)	on	DDC power is input.
	oFF	No DDC power is input.
● Input resolution		
L13(IN1), L14(IN2)	1920_1080P 60	Displaying (scroll) input resolution. (example: 1920×1080p 60 Hz)
	- - -	No signal is input.

[Table 9.48] Input status (Cont'd)

Menu number	Value to be displayed	Description
<ul style="list-style-type: none"> • Audio input type and the number of channels n*: 1 = 2 channels, 2 = 2.1 channels, 5 = 5.1 channels, 7 = 7.1 channels 		
L15(IN1), L16(IN2)	- - -	Unknown, No signal is input.
	00n*	Unknown
	01n	LINEAR PCM Audio
	02n	Dolby Digital Audio
	03n	MPEG-1 Audio
	04n	MP3 Audio
	05n	MPEG-2 Audio
	06n	AACLC Audio
	07n	DTS Audio
	08n	ATRAC Audio
	09n	DSD Audio
	10n	Dolby Digital Plus Audio
	11n	DTS-HD Audio
	12n	Dolby TrueHD Audio
	13n	DST Audio
14n	WMA Audio	
15n	HE-AAC/HE-AACv2/MPEG Surround Audio	
<ul style="list-style-type: none"> • Audio input sampling frequency 		
L17(IN1), L18(IN2)	22	22.05 kHz
	24	24 kHz
	32	32 kHz
	44	44.1 kHz
	48	48 kHz
	88	88.2 kHz
	96	96 kHz
	176	176.4 kHz
	192	192 kHz
	768	768 kHz
	_01	Unknown
	_05	
	_07	
	_11	
	_13	
_15		
- - -	No signal is input.	

[Table 9.49] Input status (Cont'd)

Menu number	Value to be displayed	Description
● The number of audio input bits, HBR mode (High Bit-Rate Audio)		
L19(IN1), L20(IN2)	H16	16 bit, HBR mode
	P16	16 bit, PCM mode
	_16	16 bit, compression audio other than HBR and PCM modes
	H20	20 bit, HBR mode
	P20	20 bit, PCM mode
	_20	20 bit, compression audio other than HBR and PCM modes
	H24	24 bit, HBR mode
	P24	24 bit, PCM mode
	_24	24 bit, compression audio other than HBR and PCM modes
	---	No signal is input.
● Audio input (Digital audio)		
L21(IN1), L22(IN2)	000	No audio is input.
	001	Input is being detected.
	002	Audio is input normally.
	---	No signal is input.
● Scrambling of input signal		
L25(IN1), L26(IN2)	on	Scrambled (4K format except for YCbCr 4:2:0)
	oFF	Not scrambled.
	---	No signal is input.
● TMDS clock ratio of input signal		
L27(IN1), L28(IN2)	1_1	1/1
	1_4	1/4 (4K format except for YCbCr 4:2:0)
	---	No signal is input.
● Input signal stream type (for HDCP 2.2)		
L29(IN1), L30(IN2)	000	Type 0
	001	Type 1
	non	HDCP 1.4 or no HDCP signal
	---	No signal is input.

[Table 9.50] Input status (WEB browser)

WEB browser menu	Value	Description
Video signal		
● Input signal resolution		
VIDEO FORMAT	1920x1080p 60.00Hz	Input resolution (example: 1920×1080p 60 Hz)
● HDMI/DVI mode of input signal		
INPUT MODE	HDMI MODE	HDMI mode
	DVI MODE	DVI mode
● Presence of input HDCP		
HDCP	HDCP2.2 Type1	HDCP2.2 stream Type1 signal
	HDCP2.2 Type0	HDCP2.2 stream Type0 signal
	HDCP1.4	HDCP1.4 signal
	NOT ENCRYPTED	No HDCP signal
● Color space of input video		
COLOR SPACE	YCbCr 4:4:4	YCbCr 4:4:4
	YCbCr 4:2:2	YCbCr 4:2:2
	YCbCr 4:2:0	YCbCr 4:2:0
	RGB	RGB
● Color depth of input signal		
DEEP COLOR	24-BIT COLOR	24 bit/pixel (8bit/component)
	30-BIT COLOR	30 bit/pixel (10bit/component)
	36-BIT COLOR	36 bit/pixel (12bit/component)
● Scrambling of input signal		
SCRAMBLE	ON	Scrambled (4K format except for YCbCr 4:2:0)
	OFF	Not scrambled.
Audio signal		
● Audio input format		
AUDIO FORMAT	LINEAR PCM	LPCM (for LPCM)
● Audio input sampling frequency		
SAMPLING FREQUENCY	48kHz	Sample frequency (for 48kHz)
● The number of audio input channels		
SPEAKER CONFIGURATION	2 CHANNEL	The number of channels (for 2 channel)
● Audio input bit (High Bit-Rate Audio)		
BIT LENGH	24BIT	Sampling bit length (for 2 channel)

9.11.2 Viewing output information

You can view the information for output.

Menu L40 to LL4

WEB menu VIEW STATUS → SINK DEVICE STATUS / SINK DEVICE EDID

[Table 9.51] Sink device status

Menu number	Value to be displayed	Description
● Deep Color		
L40(OUT1) to L44(OUT5)	24	24 bit/pixel (8 bit/component) supported
	30	30 bit/pixel (10 bit/component) supported
	36	36 bit/pixel (12 bit/component) supported
	---	Not connected
● Color space (sink)		
L50(OUT1) to L54(OUT5)	rgb	RGB supported
	422	YCbCr 4:2:2 supported
	444	YCbCr 4:4:4 supported
	444_420	Scroll display If sink device resolution is 4K@50/59.94/60, up to YCbCr 4:2:0.
	---	Not connected
● Color space (output)		
L60(OUT1) to L64(OUT5)	rgb	RGB output
	422	YCbCr 4:2:2 output
	420	YCbCr 4:2:0 output
	444	YCbCr 4:4:4 output
	---	Not connected
● Hot plug detection		
L70(OUT1) to L74(OUT5)	on	Hot plug is detected.
	oFF	No hot plug is detected.
● HDMI/DVI		
L80(OUT1) to L84(OUT5)	HC	HDMI mode (Compressed audio supported)
	HP	HDMI mode (PCM audio supported)
	d	DVI mode (Audio is not supported.)
	---	Not connected
● HDCP encryption		
L90(OUT1) to L94(OUT5)	000	None
	001	Being encrypted
	002	
	003	
	004	Encryption ends normally.
	005	Encryption ends abnormally.

[Table 9.52] Sink device status (Cont'd)

Menu number	Value to be displayed	Description
● HDCP		
LA0(OUT1) to LA4(OUT5)	1.4	HDCP 1.4 supported
	2.2	HDCP supported (HDCP 2.2)
	oFF	HDCP is not supported or no HDCP signal
	---	Not connected
● SCDC		
Lb0(OUT1) to Lb4(OUT5)	on	SCDC supported
	oFF	SCDC is not supported.
	---	Not connected
● Scrambling output		
Lc0(OUT1) to Lc4(OUT5)	on	Scrambled
	oFF	Not scrambled.
	---	Not connected
● HDR		
Ld0(OUT1) to Ld4(OUT5)	on	HDR supported
	oFF	HDR is not supported.
	---	Not connected
● 3D		
LE0(OUT1) to LE4(OUT5)	on	3D supported
	oFF	3D is not supported.
	---	Not connected
● HDCP output		
LF0(OUT1) to LF4(OUT5)	non	No HDCP output
	1.4	HDCP1.4 output
	h2.2	HDCP2.2 Type0 output
	H2.2	HDCP2.2 Type1 output
	---	Not connected
● HDMI/DVI output		
LH0(OUT1) to LH4(OUT5)	H	HDMI output
	d	DVI output
	---	Not connected
● Color range output		
LL0(OUT1) to LL4(OUT5)	L	Limited range output
	F	Full range output
	---	Not connected

[Table 9.53] Output status (WEB browser)

WEB browser menu	Value to be displayed	Description
Output signal		
● HDCP encryption		
HDCP AUTHENTICATION	HDCP2.2 SUPPORT	HDCP2.2 encryption
	HDCP1.4 SUPPORT	HDCP1.4 encryption
	HDCP CHECK NOW	Being encrypted
	HDCP NOT ENCRYPTED	HDCP is not supported.
	HDCP ERROR	Encryption ends abnormally
	HDCP NOT SUPPORT	Sink device supports HDCP.
● HDMI/DVI output		
OUTPUT MODE	HDMI MODE	HDMI output
	DVI MODE	DVI output
● Color space (output)		
COLOR SPACE	RGB	RGB output
	YCbCr4:2:2	YCbCr 4:2:2 output
	YCbCr4:4:4	YCbCr 4:4:4 output
	YCbCr4:2:0	YCbCr 4:2:0 output
● Color range output		
COLOR RANGE	LIMITED RANGE	Limited range output
	FULL RANGE	Full range output
● Deep Color		
DEEP COLOR	24-BIT COLOR	24 bit/pixel (8 bit/component) output
	30-BIT COLOR	30 bit/pixel (10 bit/component) output
	36-BIT COLOR	36 bit/pixel (12 bit/component) output
● Scrambling output		
SCRAMBLE	SCRAMBLE ON	With scramble
	SCRAMBLE OFF	No scramble
Sink device information		
● Name		
MONITOR NAME	Depending on connected device	Sink device's name
● Resolution		
RESOLUTION	Depending on connected device	Supported resolution
● HDMI/DVI		
HDMI/DVI	HDMI MODE	HDMI mode
	DVI MODE	DVI mode

[Table 9.54] Output status (WEB browser) (Cont'd)

WEB browser menu	Value to be displayed	Description
Sink device information		
• Color space		
COLOR SPACE	RGB	RGB supported
	YCbCr4:2:2	YCbCr 4:2:2 supported
	YCbCr4:4:4	YCbCr 4:4:4 supported
	YCbCr4:2:0	YCbCr 4:2:0 supported
• Deep Color		
DEEP COLOR	24-BIT COLOR	24 bit/pixel (8 bit/component) supported
	30-BIT COLOR	30 bit/pixel (10 bit/component) supported
	36-BIT COLOR	36 bit/pixel (12 bit/component) supported
• Audio sampling frequency		
PCM FREQUENCY	32kHz	32kHz supported
	44.1kHz	44.1kHz supported
	48kHz	48kHz supported
	88.2kHz	88.2kHz supported
	96kHz	96kHz supported
	176.4kHz	176.4kHz supported
	192kHz	192kHz supported
• Audio bit length		
PCM BIT LENGTH	16BIT	16BIT supported
	20BIT	20BIT supported
	24BIT	24BIT supported
• The number of audio channels		
PCM CHANNEL	2 CHANNEL	LR
	2.1 CHANNEL	2.1 channel surround sound
	5.1 CHANNEL	5.1 channel surround sound
	7.1 CHANNEL	7.1 channel surround sound
• Compressed audio		
COMPRESSED AUDIO	SUPPORTED	Compressed audio supported
	NOT SUPPORTED	Compression audio is not supported.
• HDR		
HDR	SUPPORTED	HDR supported
	NOT SUPPORTED	HDR is not supported.
• SCDC		
SCDC	SUPPORTED	SCDC supported
	NOT SUPPORTED	SCDC is not supported.

9.11.3 Viewing system status

You can view status of power voltage (DC 12V IN) and internal temperature.

Menu H00 to H02

WEB menu VIEW STATUS → SYSTEM STAUTS

[Table 9.55] System check

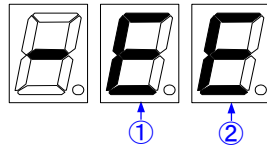

Menu number	Value (Example)	Description
● System status		
H00	-E-	① "E" is displayed in case power voltage is higher or lower than DC+12 V±10 %. ② "E" is displayed in case abnormality in internal temperature is detected. "-" is displayed when there is no problem in power voltage and internal temperature.
● Power voltage		
H01	12.0	Shows power voltage.
● Internal temperature		
H02	32.0	Shows internal temperature.

[Table 9.56] Values displayed on WEB browser

Menu number	Value (Example)	Description
● Power voltage		
POWER STATUS	12.0V STATUS: OK	Shows power voltage. [OK] : Normal [NG] : Abnormal
● Internal temperature		
TEMPERATURE STATUS	32.0C STATUS: OK	Shows internal temperature. [OK] : Normal [NG] : Abnormal

9.12 Operations only settable from WEB menu

You can operate following menus only from a WEB.

9.12.1 Editing channel name

Click the [NAME EDIT] button in [CHANNEL SELECT] menu to open the [NAME EDIT] window.

You can enter up to 10 one-byte characters.

The edited channel names are applied to the submenu tab and [STATUS] window.

9.12.2 Automatic updating time

SYSTEM SETTINGS > AUTO RELOAD TIME

You can set the automatic updating time of [CHANNEL WINDOW], [CHANNEL SELECT], and [VIEW STATUS] windows by selecting the desired value (5 to 60 seconds, 5-second interval) from [AUTO RELOAD TIME] in the [SYSTEM SETTINGS] menu.

This menu is only for [CHANNEL WINDOW], [CHANNEL SELECT], and [VIEW STATUS] windows; other windows cannot be updated automatically even if you select the desired number.

If you select [OFF] (default), [CHANNEL WINDOW], [CHANNEL SELECT], and [VIEW STATUS] windows are not updated automatically.

9.12.3 Saving/Restoring all settings

SYSTEM SETTINGS > BACKUP/RESTORE

You can save all settings to your PC.

The saved file can be restored by setting item from the [RESTORE] button. Do not perform other WEB operations or power off the HDC during the operation.

If the backup file is not correct, a warning dialog box will appear during the operation.

9.12.4 Initialization

SYSTEM SETTINGS > INITIALIZATION

You can initialize settings other than LAN communication settings by clicking the [NORMAL INITIALIZATION] button.

If you want to initialize all settings including LAN communication settings, click the [ALL INITIALIZATION] button.

10 Product specification

10.1 HDC-TR121UHD

[1/2]

Item		Description
Input		2 inputs
Output		2 outputs
Input	HDMI/DVI	1 input HDMI (*1)/DVI 1.0 TMDS single link, HDCP 1.4/2.2 HDR (*2), 3D (*3), x.v.Color EDID emulation, CEC (Pass-through) Connector: Female HDMI Type A (19-pin)
	HDBaseT	1 input HDBaseT (*4) HDCP 1.4/2.2, HDR (*2), 3D (*3), x.v.Color EDID emulation, RS-232C, LAN Connector: RJ-45 (*5) Cable: CAT.5E HDC, Cat5e UTP/STP, Cat6 UTP/STP (T568A/T568B straight-through)
Output	HDMI/DVI	1 output Output video can be distributed to an HDMI/DVI and HDBaseT simultaneously. HDMI (*1)/DVI 1.0 TMDS single link, HDCP 1.4/2.2 HDCP 1.4/2.2, HDR (*2), 3D (*3), x.v.Color, CEC (Pass-through) Connector: Female HDMI Type A (19-pin)
	HDBaseT	1 output Output video can be distributed to an HDMI/DVI and HDBaseT simultaneously. HDBaseT (*4) HDCP 1.4/2.2, HDR (*2), 3D (*3), x.v.Color, RS-232C, LAN Connector: RJ-45 (*5) Cable: CAT.5E HDC, Cat5e UTP/STP, Cat6 UTP/STP (T568A/T568B straight-through)
Format	HDMI/DVI (*6)	VGA to 4K 480i / 480p / 576i / 576p / 720p / 1080i / 1080p / 4K (up to 4K@60 (4:4:4))
	HDBaseT (*7)	VGA to 4K For WQHD/WQXGA, only Reduced Blanking is supported. 480i / 480p / 576i / 576p / 720p / 1080i / 1080p / 4K (up to 4K@60 (4:2:0))
Color depth	HDMI	24 bit, 30 bit, 36 bit Deep Color (*6)
	HDBaseT	24 bit, 30 bit, 36 bit Deep Color (*7)
Dot clock		25 MHz to 600 MHz
TMDS clock		25 MHz to 300 MHz
TMDS data rate		0.75 Gbps to 18 Gbps
Digital audio input		2 inputs Multi-channel LPCM up to 8 channels Sampling frequency: 32 kHz to 192 kHz, Sample size: 16 bit to 24 bit Reference level: -20 dBFS, Max. input level: 0 dBFS Connector: Female HDMI Type A (19-pin), RJ-45
Digital audio output		1 x 2 outputs Audio can be distributed to an HDMI output and an HDBaseT output simultaneously. Multi-channel LPCM up to 8 channels Sampling frequency: 32 kHz to 192 kHz, Sample size: 16 bit to 24 bit Reference level: -20 dBFS, Max. output level: 0 dBFS Connector: Female HDMI Type A (19-pin), RJ-45
Analog audio output		1 output Unbalanced Stereo LR Output impedance: 50 Ω, Reference level: -10 dBu, Max. output level: +10 dBu Connector: Captive screw (3-pin)
Maximum transmission distances	Digital input	HDMI/DVI : 98 ft. (30 m) (1080p@60), 39 ft. (12 m) (4K@60) (*8) HDBaseT : 328 ft. (100 m), 492 ft. (150 m) (Long reach mode is used) (*9)
	Digital output	HDMI/DVI : 98 ft. (30 m) (1080p@60), 39 ft. (12 m) (4K@60) (*8) HDBaseT : 328 ft. (100 m), 492 ft. (150 m) (Long reach mode is used) (*9)
Control	RS-232C	1 port/captive screw connector (3-pin), full duplex, up to 38.4 kbps
	LAN	1 port/RJ-45 10Base-T/100Base-TX (Auto Negotiation), Auto MDI/MDI-X
Functions		WEB browser control, Input channel automatic switching, Anti-snow, Connection Reset (*10), Button security lockout, OUT1 supports down conversion (4K to 1080p)

Item	Description
General	AC adapter Input : 100 - 240 VAC ± 10%, 50 Hz/60 Hz ± 3 Hz Output : DC 12 V 3 A (A dedicated AC adapter is provided)
	Power consumption About 15 Watts
	Dimensions 8.3 (W) × 1.2 (H) × 7.9 (D)" (210 (W) × 30 (H) × 200 (D) mm) (Half rack wide, thin type) (Excluding connectors and the like)
	Weight 2.9 lbs. (1.3 kg)
	Temperature Operating : 32°F to 104°F (0°C to +40°C) Storage : -4°F to +176°F (-20°C to +80°C)
	Humidity Operating/Storage: 20% to 90% (Non Condensing)

- *1 ARC and HEC are not supported.
- *2 HDR is supported if external EDID is selected while an HDR-supported sink device is connected for EDID setting or if copied EDID of an HDR-supported sink device is selected for EDID setting. Input HDR signal is output from all output connectors.
- *3 3D is supported if external EDID is selected while a 3D-supported sink device is connected for EDID setting or if copied EDID of 3D-supported sink device is selected for EDID setting. Input 3D signal is output from all output connectors.
- *4 ARC, HEC and CEC are not supported.
- *5 RJ-45 (HDBaseT connector) is only for extending digital video and audio signals over a Cat5e/Cat6 cable. Use it with IDK's HDBaseT Products. Do not use for LAN devices.
- *6 For 4K format, the following color depths are supported.
 - 24 Hz/25 Hz/30 Hz : 24 bit, 30 bit, 36 bit (RGB, YCbCr 4:4:4, YCbCr 4:2:2)
 - 50 Hz/59.94 Hz/60 Hz : 24 bit, 30 bit, 36 bit (YCbCr 4:2:2, YCbCr 4:2:0)
 - 24 bit (RGB, YCbCr 4:4:4)
- *7 For 4K format, the following color depths are supported.
 - 24 Hz/25 Hz/30 Hz : 24 bit (RGB, YCbCr 4:4:4, YCbCr 4:2:2)
 - 50 Hz/59.94 Hz/60 Hz : only 24 bit (YCbCr 4:2:0) and CEA-861
- *8 The maximum cable distance varies depending on the connected devices and was measured under following conditions:
 - 1080p@60: When IDK's 24 AWG cable was used and signals of 1080p@60 24 bit/pixel (8 bit/component) was input or output.
 - 4K@60 : When IDK's 18 Gbps supported cable was used and signals of 4K@60 24 bit/pixel (8 bit/component) was input or output
 The maximum cable distance depends on the connected devices. The distance may not be extended with some device combinations, cabling method, or other manufacturers' cable. Video may be disturbed or may not be output even if signals are within the range mentioned above.
- *9 The maximum transmission distance was obtained when IDK's CAT.5E HDC cable was used. The distance may not be extended with some device combinations, cabling method, or other manufacturer's cable. Video may be disturbed or may not be output even if signals are within the range mentioned above. The maximum transmission distance is the shorter distance of connected HDBaseT product or sink device's maximum transmission distance. Up to 492 ft. (150 m): 1080p (24 bit) in Long reach mode. For Long reach mode, use IDK's HDBaseT Products that supports 328 ft. (100 m) or longer.
- *10 For digital systems, some problems, such as an HDCP authentication error, can often be recovered by physically disconnecting and reconnecting the digital cables. However, the Connection Reset feature will fix these problems automatically without the need to physically plug and unplug the cables. It creates the same condition as if the cable were physically disconnected and reconnected. This feature only works for the HDC's output. If other devices are connected between the HDC's output and sink device, this feature may be invalid.

10.2 HDC-TH221UHD/HDC-TH421UHD

[1/2]

Item		Description	
		HDC-TH221UHD	HDC-TH421UHD
Input	HDMI/DVI	1 input HDMI (*1)/DVI 1.0 TMDS single link, HDCP 1.4/2.2 HDR (*2), 3D (*3), x.v.Color EDID emulation, CEC (Pass-through) Connector: Female HDMI Type A (19-pin)	
	HDBaseT	1 input HDBaseT (*4) HDCP 1.4/2.2, HDR (*2), 3D (*3), x.v.Color EDID emulation, RS-232C, LAN Connector: RJ-45 (*5) Cable: CAT.5E HDC, Cat5e UTP/STP, Cat6 UTP/STP (T568A/T568B straight-through)	
Output	HDMI/DVI	1 output Video can be distributed to an HDMI/DVI output and HDBaseT outputs simultaneously. HDMI (*1)/DVI 1.0 TMDS single link, HDCP 1.4/2.2 HDR (*2), 3D (*3), x.v.Color, CEC (Pass-through) Connector: Female HDMI Type A (19-pin)	
	HDBaseT	1 x 2 outputs Video can be distributed to an HDMI/DVI output and HDBaseT outputs simultaneously. HDBaseT (*4) HDCP 1.4/2.2, HDR (*2), 3D (*3), x.v.Color, RS-232C, LAN Connector: RJ-45 (*5) Cable: CAT.5E HDC, Cat5e UTP/STP, Cat6 UTP/STP (T568A/T568B straight-through)	1 x 4 outputs Video can be distributed to an HDMI/DVI output and HDBaseT outputs simultaneously. HDBaseT (*4) HDCP 1.4/2.2, HDR (*2), 3D (*3), x.v.Color, RS-232C, LAN Connector: RJ-45 (*5) Cable: CAT.5E HDC, Cat5e UTP/STP, Cat6 UTP/STP (T568A/T568B straight-through)
Format	HDMI/DVI (*6)	VGA to 4K 480i / 480p / 576i / 576p / 720p / 1080i / 1080p / 4K (up to 4K@60 (4:4:4))	
	HDBaseT (*7)	VGA to 4K For WQHD/WQXGA, only Reduced Blanking is supported. 480i / 480p / 576i / 576p / 720p / 1080i / 1080p / 4K (up to 4K@60 (4:2:0))	
Color depth	HDMI	24 bit, 30 bit, 36 bit Deep Color (*6)	
	HDBaseT	24 bit, 30 bit, 36 bit Deep Color (*7)	
Dot clock	25 MHz to 600 MHz		
TMDS clock	25 MHz to 300 MHz		
TMDS data rate	0.75 Gbps to 18 Gbps		
Digital audio input	2 inputs Multi-channel LPCM up to 8 channels Sampling frequency: 32 kHz to 192 kHz, Sample size: 16 bit to 24 bit Reference level: -20 dBFS, Max. input level: 0 dBFS Connector: Female HDMI Type A (19-pin), RJ-45		
Digital audio output	1 x 3 outputs Audio can be distributed to an HDMI output and HDBaseT outputs simultaneously. Multi-channel LPCM up to 8 channels Sampling frequency: 32 kHz to 192 kHz Sample size: 16 bit to 24 bit Reference level: -20 dBFS Max. output level: 0 dBFS Connector: Female HDMI Type A (19-pin), 2 RJ-45s	1 x 5 outputs Audio can be distributed to an HDMI output and HDBaseT outputs simultaneously. Multi-channel LPCM up to 8 channels Sampling frequency: 32 kHz to 192 kHz Sample size: 16 bit to 24 bit Reference level: -20 dBFS Max. output level: 0 dBFS Connector: Female HDMI Type A (19-pin), 4 RJ-45s	
Analog audio output	1 output Unbalanced Stereo LR Output impedance: 50 Ω, Reference level: -10 dBu, Max. output level: +10 dBu Connector: Captive screw (3-pin)		
Maximum transmission distances	Digital input	HDMI/DVI : 98 ft. (30 m) (1080p@60), 39 ft. (12 m) (4K@60) (*8) HDBaseT : 328 ft. (100 m), 492 ft. (150 m) (Long reach mode is used) (*9)	
	Digital output	HDMI/DVI : 98 ft. (30 m) (1080p@60), 39 ft. (12 m) (4K@60) (*8) HDBaseT : 328 ft. (100 m), 492 ft. (150 m) (Long reach mode is used) (*9)	
Control	RS-232C	1 port/captive screw connector (3-pin), full duplex, up to 38.4 kbps	
	LAN	1 port/RJ-45 10Base-T/100Base-TX (Auto Negotiation), Auto MDI/MDI-X	
Functions	WEB browser control, Input channel automatic switching, Anti-snow, Connection Reset (*10), Button security lockout, OUT1 supports down conversion (4K to 1080p)		

Item	Description	
	HDC-TH221UHD	HDC-TH421UHD
General	AC adapter	Input : 100 - 240 VAC ± 10%, 50 Hz/60 Hz ± 3 Hz Output : DC 12 V 3 A (A dedicated AC adapter is provided)
	Power consumption	About 22 Watts About 31 Watts
	Dimensions	8.3 (W) × 1.7 (H) × 7.9 (D)" (210 (W) × 44 (H) × 200 (D) mm) (Half rack wide, 1U high) (Excluding connectors and the like)
	Weight	3.5 lbs. (1.6 kg) 3.5 lbs. (1.6 kg)
	Temperature	Operating : 32°F to 104°F (0°C to +40°C) Storage : -4°F to +176°F (-20°C to +80°C)
	Humidity	Operating/Storage: 20% to 90% (Non Condensing)

- *1 ARC and HEC are not supported.
- *2 HDR is supported if external EDID is selected while an HDR-supported sink device is connected for EDID setting or if copied EDID of an HDR-supported sink device is selected for EDID setting. Input HDR signal is output from all output connectors.
- *3 3D is supported if external EDID is selected while a 3D-supported sink device is connected for EDID setting or if copied EDID of 3D-supported sink device is selected for EDID setting. Input 3D signal is output from all output connectors.
- *4 ARC, HEC and CEC are not supported.
- *5 RJ-45 (HDBaseT connector) is only for extending digital video and audio signals over a Cat5e/Cat6 cable. Use it with IDK's HDBaseT Products. Do not use for LAN devices.
- *6 For 4K format, the following color depths are supported.
 - 24 Hz/25 Hz/30 Hz : 24 bit, 30 bit, 36 bit (RGB, YCbCr 4:4:4, YCbCr 4:2:2)
 - 50 Hz/59.94 Hz/60 Hz : 24 bit, 30 bit, 36 bit (YCbCr 4:2:2, YCbCr 4:2:0)
 - : 24 bit (RGB, YCbCr 4:4:4)
- *7 For 4K format, the following color depths are supported.
 - 24 Hz/25 Hz/30 Hz : 24 bit (RGB, YCbCr 4:4:4, YCbCr 4:2:2)
 - 50 Hz/59.94 Hz/60 Hz : Only 24 bit (YCbCr 4:2:0) and CEA-861
- *8 The maximum cable distance varies depending on the connected devices and was measured under following conditions:
 - 1080p@60: When IDK's 24 AWG cable was used and signals of 1080p@60 24 bit/pixel (8 bit/component) was input or output.
 - 4K@60 : When IDK's 18 Gbps supported cable was used and signals of 4K@60 24 bit/pixel (8 bit/component) was input or output
 The maximum cable distance depends on the connected devices. The distance may not be extended with some device combinations, cabling method, or other manufacturer's cable. Video may be disturbed or may not be output even if signals are within the range mentioned above.
- *9 The maximum transmission distance was obtained when IDK's CAT.5E HDC cable was used. The distance may not be extended with some device combinations, cabling method, or other manufacturer's cable. Video may be disturbed or may not be output even if signals are within the range mentioned above. The maximum transmission distance is the shorter distance of connected HDBaseT product or sink device's maximum transmission distance. Up to 492 ft. (150 m): 1080p (24 bit) in Long reach mode. For Long reach mode, use IDK's HDBaseT Products that supports 328 ft. (100 m) or longer.
- *10 For digital systems, some problems, such as an HDCP authentication error, can often be recovered by physically disconnecting and reconnecting the digital cables. However, the Connection Reset feature will fix these problems automatically without the need to physically plug and unplug the cables. It creates the same condition as if the cable were physically disconnected and reconnected. This feature only works for the HDC's output. If other devices are connected between the HDC's output and sink device, this feature may be invalid.

10.3 HDC-RH221UHD/HDC-RH421UHD

[1/2]

Item		Description	
		HDC-RH221UHD	HDC-RH421UHD
Input	HDMI/DVI	1 input HDMI (*1)/DVI 1.0 TMDS single link, HDCP 1.4/2.2 HDR (*2), 3D (*3), x.v.Color EDID emulation, CEC (Pass-through) Connector: Female HDMI Type A (19-pin)	
	HDBaseT	1 input HDBaseT (*4) HDCP 1.4/2.2, HDR (*2), 3D (*3), x.v.Color EDID emulation, RS-232C, LAN Connector: RJ-45 (*5) Cable: CAT.5E HDC, Cat5e UTP/STP, Cat6 UTP/STP (T568A/T568B straight-through)	
Output	HDMI/DVI	1 x 2 outputs Video can be distributed to HDMI/DVI outputs and an HDBaseT output simultaneously. HDMI (*1)/DVI 1.0 TMDS single link, HDCP 1.4/2.2 HDR (*2), 3D (*3), x.v.Color, Only OUT1 supports CEC (Pass-through) Connector: Female HDMI Type A (19-pin)	1 x 4 outputs Video can be distributed to HDMI/DVI outputs and an HDBaseT output simultaneously. HDMI (*1)/DVI 1.0 TMDS single link, HDCP 1.4/2.2 HDR (*2), 3D (*3), x.v.Color, Only OUT1 supports CEC (Pass-through) Connector: Female HDMI Type A (19-pin)
	HDBaseT	1 output Video can be distributed to HDMI/DVI outputs and an HDBaseT output simultaneously. HDCP 1.4/2.2, HDR (*2), 3D (*3), x.v.Color, RS-232C, LAN Connector: RJ-45 (*5) Cable: CAT.5E HDC, Cat5e UTP/STP, Cat6 UTP/STP (T568A/T568B straight-through)	
Format	HDMI/DVI (*6)	VGA to 4K 480i / 480p / 576i / 576p / 720p / 1080i / 1080p / 4K (up to 4K@60 (4:4:4))	
	HDBaseT (*7)	VGA to 4K For WQHD/WQXGA, only Reduced Blanking is supported. 480i / 480p / 576i / 576p / 720p / 1080i / 1080p / 4K (up to 4K@60 (4:2:0))	
Color depth	HDMI	24 bit, 30 bit, 36 bit Deep Color (*6)	
	HDBaseT	24 bit, 30 bit, 36 bit Deep Color (*7)	
Dot clock		25 MHz to 600 MHz	
TMDS clock		25 MHz to 300 MHz	
TMDS data rate		0.75 Gbps to 18 Gbps	
Digital audio input		2 inputs Multi-channel LPCM up to 8 channels Sampling frequency: 32 kHz to 192 kHz, Sample size: 16 bit to 24 bit, Reference level: -20 dBFS, Max. input level: 0 dBFS Connector: Female HDMI Type A (19-pin), RJ-45	
Digital audio output		1 x 3 outputs Audio can be distributed to HDMI outputs and an HDBaseT output simultaneously. Multi-channel LPCM up to 8 channels Sampling frequency: 32 kHz to 192 kHz Sample size: 16 bit to 24 bit Reference level: -20 dBFS, Max. output level: 0 dBFS Connector: Female HDMI Type A (19-pin), 2 RJ-45s	1 x 5 outputs Audio can be distributed to HDMI outputs and an HDBaseT output simultaneously. Multi-channel LPCM up to 8 channels Sampling frequency: 32 kHz to 192 kHz Sample size: 16 bit to 24 bit Reference level: -20 dBFS Max. output level: 0 dBFS Connector: Female HDMI Type A (19-pin), 4 RJ-45s
Analog audio output		1 output Unbalanced Stereo LR Output impedance: 50 Ω, Reference level: -10 dBu, Max. output level: +10 dBu Connector: Captive screw (3-pin)	
Maximum transmission distances	Digital input	HDMI/DVI : 98 ft. (30 m) (1080p@60), 39 ft. (12 m) (4K@60) (*8) HDBaseT : 328 ft. (100 m), 492 ft. (150 m) (Long reach mode is used) (*9)	
	Digital output	HDMI/DVI : 98 ft. (30 m) (1080p@60), 39 ft. (12 m) (4K@60) (*8) HDBaseT : 328 ft. (100 m), 492 ft. (150 m) (Long reach mode is used) (*9)	
Control	RS-232C	1 port/captive screw connector (3-pin), full duplex, up to 38.4 kbps	
	LAN	1 port/RJ-45 10Base-T/100Base-TX (Auto Negotiation), Auto MDI/MDI-X	
Functions		WEB browser control, Input channel automatic switching, Anti-snow, Connection Reset (*10), Button security lockout, OUT1 supports down conversion (4K to 1080p)	

Item	Description	
	HDC-RH221UHD	HDC-RH421UHD
General	AC adapter	Input : 100 - 240 VAC ± 10%, 50 Hz/60 Hz ± 3 Hz Output : DC 12 V 3 A (A dedicated AC adapter is provided)
	Power consumption	About 20 Watts About 24 Watts
	Dimensions	8.3 (W) × 1.7 (H) × 7.9 (D)" (210 (W) × 44 (H) × 200 (D) mm) (Half rack wide, 1U high) (Excluding connectors and the like)
	Weight	3.5 lbs. (1.6 kg) 3.5 lbs. (1.6 kg)
	Temperature	Operating : 32°F to 104°F (0°C to +40°C) Storage : -4°F to +176°F (-20°C to +80°C)
	Humidity	Operating/Storage: 20% to 90% (Non Condensing)

- *1 ARC and HEC are not supported.
- *2 HDR is supported if external EDID is selected while an HDR-supported sink device is connected for EDID setting or if copied EDID of an HDR-supported sink device is selected for EDID setting. Input HDR signal is output from all output connectors.
- *3 3D is supported if external EDID is selected while a 3D-supported sink device is connected for EDID setting or if copied EDID of 3D-supported sink device is selected for EDID setting. Input 3D signal is output from all output connectors.
- *4 ARC, HEC and CEC are not supported.
- *5 RJ-45 (HDBaseT connector) is only for extending digital video and audio signals over a Cat5e/Cat6 cable. Use it with IDK's HDBaseT Products. Do not use for LAN devices.
- *6 For 4K format, the following color depths are supported.
 - 24 Hz/25 Hz/30 Hz : 24 bit, 30 bit, 36 bit (RGB, YCbCr 4:4:4, YCbCr 4:2:2)
 - 50 Hz/59.94 Hz/60 Hz : 24 bit, 30 bit, 36 bit (YCbCr 4:2:2, YCbCr 4:2:0)
 - : 24 bit (RGB, YCbCr 4:4:4)
- *7 For 4K format, the following color depths are supported.
 - 24 Hz/25 Hz/30 Hz : 24 bit (RGB, YCbCr 4:4:4, YCbCr 4:2:2)
 - 50 Hz/59.94 Hz/60 Hz : only 24 bit (YCbCr 4:2:0) and CEA-861
- *8 The maximum cable distance varies depending on the connected devices and was measured under following conditions:
 - 1080p@60: When IDK's 24 AWG cable was used and signals of 1080p@60 24 bit/pixel (8 bit/component) was input or output.
 - 4K@60 : When IDK's 18 Gbps supported cable was used and signals of 4K@60 24 bit/pixel (8 bit/component) was input or output
 The maximum cable distance depends on the connected devices. The distance may not be extended with some device combinations, cabling method, or other manufacturer's cable. Video may be disturbed or may not be output even if signals are within the range mentioned above.
- *9 The maximum transmission distance was obtained when IDK's CAT.5E HDC cable was used. The distance may not be extended with some device combinations, cabling method, or other manufacturer's cable. Video may be disturbed or may not be output even if signals are within the range mentioned above. The maximum transmission distance is the shorter distance of connected HDBaseT product or sink device's maximum transmission distance. Up to 492 ft. (150 m): 1080p (24 bit) in Long reach mode. For Long reach mode, use IDK's HDBaseT Products that supports 328 ft. (100 m) or longer.
- *10 For digital systems, some problems, such as an HDCP authentication error, can often be recovered by physically disconnecting and reconnecting the digital cables. However, the Connection Reset feature will fix these problems automatically without the need to physically plug and unplug the cables. It creates the same condition as if the cable were physically disconnected and reconnected. This feature only works for the HDC's output. If other devices are connected between the HDC's output and sink device, this feature may be invalid.

Problem	Cause/Check item/Solution	Page
● Video output (Cont'd)		
Video is not being output.	[5] Is the resolution supported by the sink device? Check the resolution and video frequency. Sink device's resolution may not be supported. Check the specification of the sink device.	83 [L07]
	[6] Does the sink device support SCDC? ① Check TMD5 clock ratio of input signal. • 1_4 : SCDC signal • 1_1 : Not SCDC signal. There may be another problem. ② Check if the sink device supports SCDC. • on : SCDC supported. • oFF : SCDC is not supported; vide is not displayed.	85 [L21] 88 [LAn]
	[7] Step 1: Check input signal stream type. • 000 : Video is displayed to all HDCP 1.4/ HDCP 2.2-compliant devices. • 001 : Video is displayed only to HDCP 2.2-compliant devices. Step 2: Check if HDCP is supported.	85 [L22] 87 [L90]
	[8] Change the setting of Hot plug ignoring duration.	71 [C1n]
	[9] If a long cable is connected for input or output, replace it with a 16 ft. (5 m) or shorter cable. Even though a 16 ft. (5 m) or longer cable can be connected for digital I/O of the HDC, HDCP authorization or EDID acquisition may fail depending on the cable quality and the connected device. For 4K format, check " 5 System Configuration Example ".	23
	[10] The time setting for monitoring no-signal input may be too short.	69 [F16]
	[11] Check the video output setting of the source device.	—
	If Long reach mode is set to enabled, only up to 1080p (24 bit) or 148 MHz can be transmitted.	74 [C4n]

Problem	Cause/Check item/Solution	Page
● Video output (Cont'd)		
Video is intermittent, or presents noise.	If using a long cable for input or output, replace it with a 16.4 ft. (5 m) or shorter cable. Since the HDC has automatic cable length equalization, long cables can be successfully used, but the HDC's full performance may not be realized if the cable or connected peripheral devices are of inferior quality. If the error is solved by replacing the cable, the signal may have been degraded due to excessive attenuation or crosstalk. IDK offers high-quality cables, cable boosters and extenders. Please contact us as needed. For 4K format, check " 5 System Configuration Example ".	23
	The transmission clock of Deep Color signal is faster than that of normal signal. If lo-quality or long cable is used, noise may appear. You can control Deep Color of input signal by setting EDID.	58 [F20]
Video flickers	If an interlace signal is input to a sink device that does not support interlace inputs, the video may flicker. Check the format settings for the HDC's output port driving the sink device.	53 [F10]
The left, right, top and bottom sides are cut off.	Some sink devices overscan input video, and the video may be cut out. Check the display setting of the sink device.	—
Video is reduced vertically or horizontally.	Some sink devices display input video with full screen mode, and the aspect ratio cannot be kept. Check the display setting of the sink device. With some resolutions, full-screen display cannot be avoided. In that case, change the output resolution of the source device.	—
Black is displayed at top, bottom, right and left on PC video or only part of the PC video is displayed, and the rest can be revealed by scrolling with the mouse.	If the PC has the Panel Fit function, select [Scale Full Screen]. If the resolution that is set for the PC and the resolution that is actually output from the PC are not matched, those problems may occur. Check the resolution of the PC and the EDID resolution setting.	53 [F10]
PC's dual monitor cannot be set or the setting is canceled.	If the monitoring function for no-signal input is enabled, the dual monitor function of your PC may not work correctly. In this case, disable the monitoring function.	69 [F16]

Problem	Cause/Check item/Solution	Page
● Video output (Cont'd)		
Downconverted signal is not output.	Does the input resolution support downconversion? Check the input resolution. For HDC, only OUT1 supports downconversion.	74 [C40]
● Audio output		
Video is displayed, but audio is not output.	Ensure that audio output is turned on.	64 [F7n]
	If there are multiple output connectors in the source device, check the audio output setting of the source device.	—
	Ensure that the input audio format is supported by the connected sink device. Typically, LCD monitors may not output 88.2 kHz or higher sampling frequency of LPCM and compressed audio (such as Dolby Digital, DTS, and other format). In order to play a Blu-ray disc having compressed audio, check the audio output setting of the source device. The source device's audio signal characteristics can be managed by the HDC's EDID configuration settings.	58 [F22] to 61 [F34]
	Ensure that DVI signal is not being output from the source device.	—
Even though multi-channel audio is played, only 2-channel audio is output	For multi-channel, change the EDID setting which is set to 2-channel audio by default.	62 [F36]
Audio is output from HDMI outputs but not from analog audio outputs.	If compressed audio (such as Dolby Digital, DTS, and other formats) is applied to the input, analog audio is not provided at output. Only 2-channel LPCM is supported.	58 [F22] to 61 [F34]
Audio is output from analog audio outputs but not from HDMI outputs.	Is audio output enabled?	64 [F7n]
	Is the selected resolution supported by the connected sink device? If a PC output resolution (XGA to WQXGA) is selected, some sink devices cannot output audio.	53 [F10]
	Is the selected sampling frequency supported by the connected sink device? Some LCD monitors may not output audio if the sampling frequency is high (typically 88.2 kHz or higher). Audio signal that is output from the source device can be controlled by changing EDID setting.	58 [F22] to 61 [F34]

Problem	Cause/Check item/Solution	Page
● Audio output (Cont'd)		
Compressed audio (such as Dolby Digital, DTS) is not output from the source device.	Compressed audio input is set to OFF (EDID settings) by factory default. If using compressed audio, change the EDID setting.	58 [F22] to 61 [F34]
	Check the audio output settings of the source device.	—
● Communication command, WEB browser control		
Control commands and WEB browser cannot be issued from PC to the HDC.	Are IP address and subnet mask set correctly? For using WEB browser, check if the setting for TCP port connection is enabled for WEB browser.	
● Others		
Devices cannot be controlled through CEC.	To use CEC, enable the HDMI link control of the connected devices (such as LCD TVs, Blu-ray recorder, and other formats). CEC is supported only between IN1 and OUT1.	—

If additional assistance is required, please perform the following tests and then contact us.

No.	Checking items	Result
1	The problem occurs at all connectors?	Yes or No
2	Connect the devices using genuine cables without connecting the HDC. The problem still cannot be solved? Please contact us for assistance.	Yes or No

User Guide of HDC-UHD Series

Ver.1.0.0

Issued on: 25 January 2020



Headquarters

IDK Corporation
7-9-1 Chuo, Yamato-shi, Kanagawa-pref.
242-0021 JAPAN
TEL: +81-46-200-0764 FAX: +81-46-200-0765

Email: idk_eng@idk.co.jp URL: <http://www.idkav.com>

USA

IDK America Inc.
72 Grays Bridge Road Suite 1-C, Brookfield, CT 06804
TEL: +1-203-204-2445

Email: sales@idkav.com URL: <http://www.idkav.com>

Europe

IDK Europe GmbH
Lise-Meitner-Str. 6, D-40878 Ratingen
TEL: +49-2102-578-301-0

Email: info@idkav.eu URL: <http://www.idkav.com>



Product information Support

Arvanics Corporation
7-9-1 Chuo, Yamato-shi, Kanagawa-pref.
242-0021 JAPAN
TEL: +81-46-259-6920 FAX: +81-46-259-6930

Email: info@arvanics.com URL: <http://www.arvanics.com>

Information in this document is subject to change without notice.

©2020 IDK Corporation, all rights reserved. All trademarks mentioned are the property of their respective owners.